

Product Features

- ✧ Multi-rate operation, optimized at 2.5Gb/s
- ✧ 1310nm DFB laser and PIN photo detector for 20km transmission
- ✧ Compliant with SFP MSA and SFF-8472 with duplex LC receptacle
- ✧ Digital Diagnostic Monitor Interface
- ✧ Very low EMI and excellent ESD protection
- ✧ +3.3V single power supply
- ✧ RoHS compliant
- ✧ Temperature range:
 - Commercial: 0°C to 70°C
 - Extended: -10°C to +80°C
 - Industrial: -40°C to +85°C



Applications

- ✧ SDH STM-16 and SONET OC-48 system
- ✧ 2X Fiber Channel
- ✧ Switch to Switch interface
- ✧ Switched backplane applications
- ✧ Router/Server interface
- ✧ Other optical transmission systems

Ordering Information

Part Number	Output Power	Rec. Sens	Data Rate	Wavelength	Distance
FH-S3125XDL20	-6~+1dBm	-18dBm	2.5G	1310nm	20km

General

The SFP transceivers are high performance, cost effective modules supporting dual data-rate of 2.5Gbps and 20km transmission distance with SMF.

The transceiver consists of three sections: a DFB laser transmitter, a PIN photodiode integrated with a trans-impedance preamplifier (TIA) and MCU control unit. All modules satisfy class I laser safety requirements.

The transceivers are compatible with SFP Multi-Source Agreement (MSA) and SFF-8472. For further information, please refer to SFP MSA.

Absolute Maximum Ratings

Parameter	Symbol	Min.	Max.	Unit	Note
Supply Voltage	Vcc	-0.5	3.60	V	
Storage Temperature		-40	85	°C	
Relative Humidity		5	85	%	

Note: Stress in excess of the maximum absolute ratings can cause permanent damage to the module

General Operating Characteristics

Parameter	Symbol	Min.	Typ	Max.	Unit	Note
Data Rate			2.5		Gb/s	
Supply Voltage	Vcc	3.13	3.3	3.47	V	
Supply Current	Icc			220	mA	
Operating Case Temp.	Tc	0		70	°C	
		-10		80		
		-45		85		

Electrical Input/Output Characteristics

Parameter		Symbol	Min.	Typical	Max.	Unit	Notes
Transmitter							
Diff. input voltage swing			300		1800	mVpp	1
Tx Disable input	H	VIH	2.0		Vcc+0.3	V	
	L	VIL	0		0.8		
Tx Fault output	H	VOH	2.0		Vcc+0.3	V	2
	L	VOL	0		0.5		
Input Diff. Impedance		Zin		100		Ω	
Receiver							
Diff. output voltage swing			400		1000	mVpp	1
Rx LOS Output	H	VOH	2.0		Vcc+0.3	V	2
	L	VOL	0		0.8		

Note 1) AC-Coupled CML logic family.

Note 2) Tx Fault and Rx LOS are open collector outputs, which should be pulled up with 4.7k to 10kΩ resistors on the host board. Pull up voltage between 2.0V and Vcc+0.3V.

Optical Characteristics

Parameter	Symbol	Min.	Typ	Max.	Unit	Note
Transmitter						
Operating Wavelength		1270	1310	1360	nm	
Ave. output power (Enabled)	Po	-6		1	dBm	1
Extinction Ratio	ER	8.5			dB	1
RMS spectral width	$\Delta\lambda$			1	nm	
Side mode Suppression Ratio	SMSR	30			dB	
Output Optical Eye	Compliant with ITU-T G.957					
Receiver						
Operating Wavelength		1270		1610	nm	
Sensitivity	Psen			-18	dBm	3
Min. overload	Pimax	-3			dBm	3
LOS Assert	Pa	-30			dBm	
LOS De-assert	Pd			-19	dBm	
LOS Hysteresis	Pd-Pa	0.5		6	dB	

Note 1) Measured at 2488 Mb/s with PRBS 223 – 1 NRZ test pattern.

Note 2) Meet the specified maximum output jitter requirements if the specified maximum input jitter is present

Note 3) Measured at 2488 Mb/s with PRBS 223 – 1 NRZ test pattern for BER < 1x10⁻¹⁰

Pin Definitions And Functions

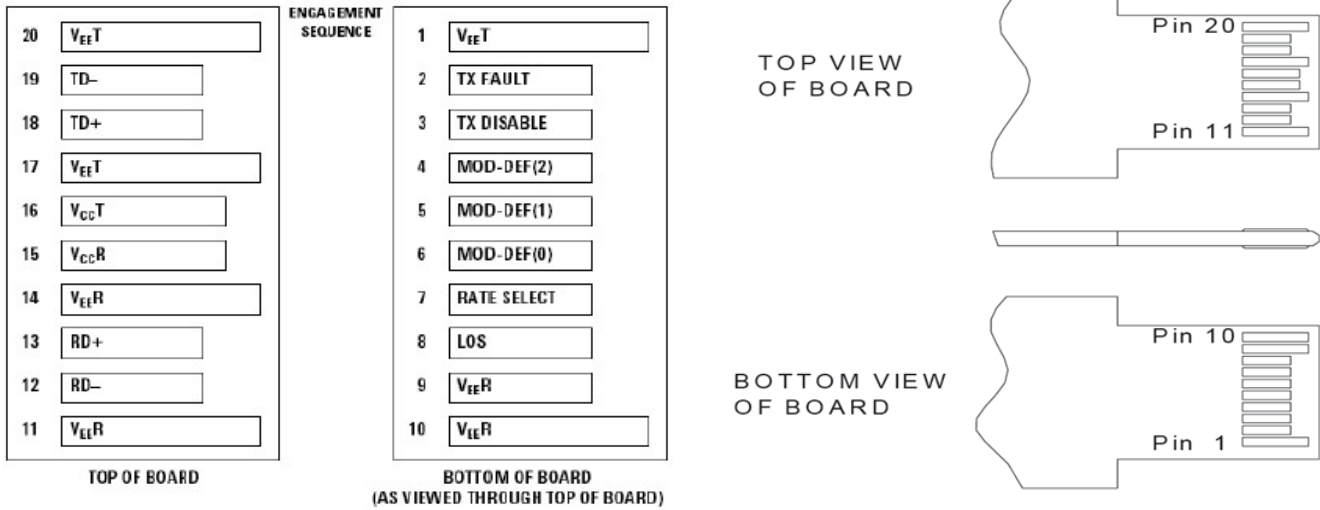

PIN #	Name	Function	Notes
1	V _{EE} T	Tx ground	
2	Tx Fault	Tx fault indication, Open Collector Output, active “H”	Note 1
3	Tx Disable	LVTTL Input, internal pull-up, Tx disabled on “H”	Note 2
4	MOD-DEF2	2 wire serial interface data input/output (SDA)	Note 3
5	MOD-DEF1	2 wire serial interface clock input (SCL)	Note 3
6	MOD-DEF0	Model present indication	Note 3
7	Rate select	No connection	
8	LOS	Rx loss of signal, Open Collector Output, active “H”	Note 4
9	V _{EE} R	Rx ground	
10	V _{EE} R	Rx ground	
11	V _{EE} R	Rx ground	
12	RD-	Inverse received data out	Note 5
13	RD+	Received data out	Note 5
14	V _{EE} R	Rx ground	
15	V _{CC} R	Rx power supply	
16	V _{CC} T	Tx power supply	
17	V _{EE} T	Tx ground	
18	TD+	Transmit data in	Note 6
19	TD-	Inverse transmit data in	Note 6
20	V _{EE} T	Tx ground	

Note 1) When high, this output indicates a laser fault of some kind. Low indicates normal operation. And should be pulled up with a 4.7 – 10KΩ resistor on the host board.

Note 2) TX disable is an input that is used to shut down the transmitter optical output. It is pulled up within the module with a 4.7 – 10KΩ resistor. Its states are:

Low (0 – 0.8V): Transmitter on ($>0.8, < 2.0V$): Undefined

High (2.0V~Vcc+0.3V): Transmitter Disabled Open: Transmitter Disabled

Note 3) Mod-Def 0,1,2. These are the module definition pins. They should be pulled up with a 4.7K – 10KΩ resistor on the host board. The pull-up voltage shall be between 2.0V~Vcc+0.3V.

Mod-Def 0 has been grounded by the module to indicate that the module is present

Mod-Def 1 is the clock line of two wire serial interface for serial ID

Mod-Def 2 is the data line of two wire serial interface for serial ID

Note 4) When high, this output indicates loss of signal (LOS). Low indicates normal operation.

Note 5) RD+/-: These are the differential receiver outputs. They are AC coupled 100Ω differential lines which should be terminated with 100Ω (differential) at the user SERDES. The AC coupling is done inside the module and is thus not required on the host board.

Note 6) TD+/-: These are the differential transmitter inputs. They are AC-coupled, differential lines with 100Ω differential termination inside the module. The AC coupling is done inside the module and is thus not required on the host board.

Typical Interface Circuit

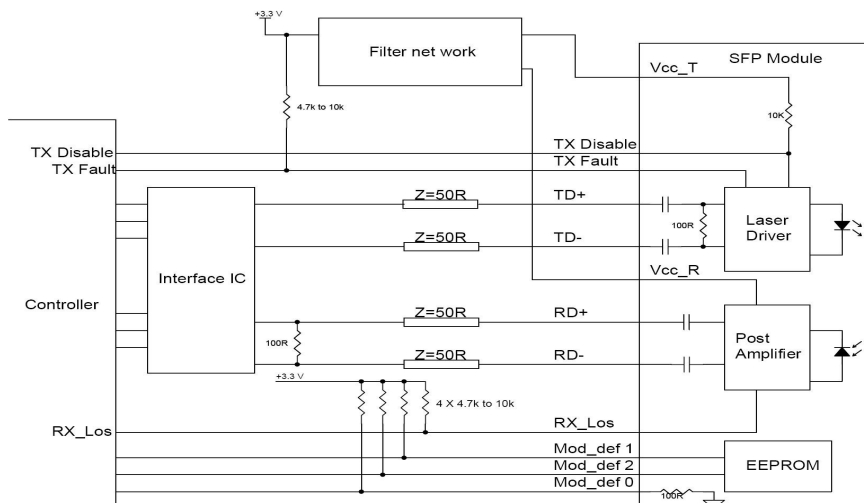

Package Dimensions

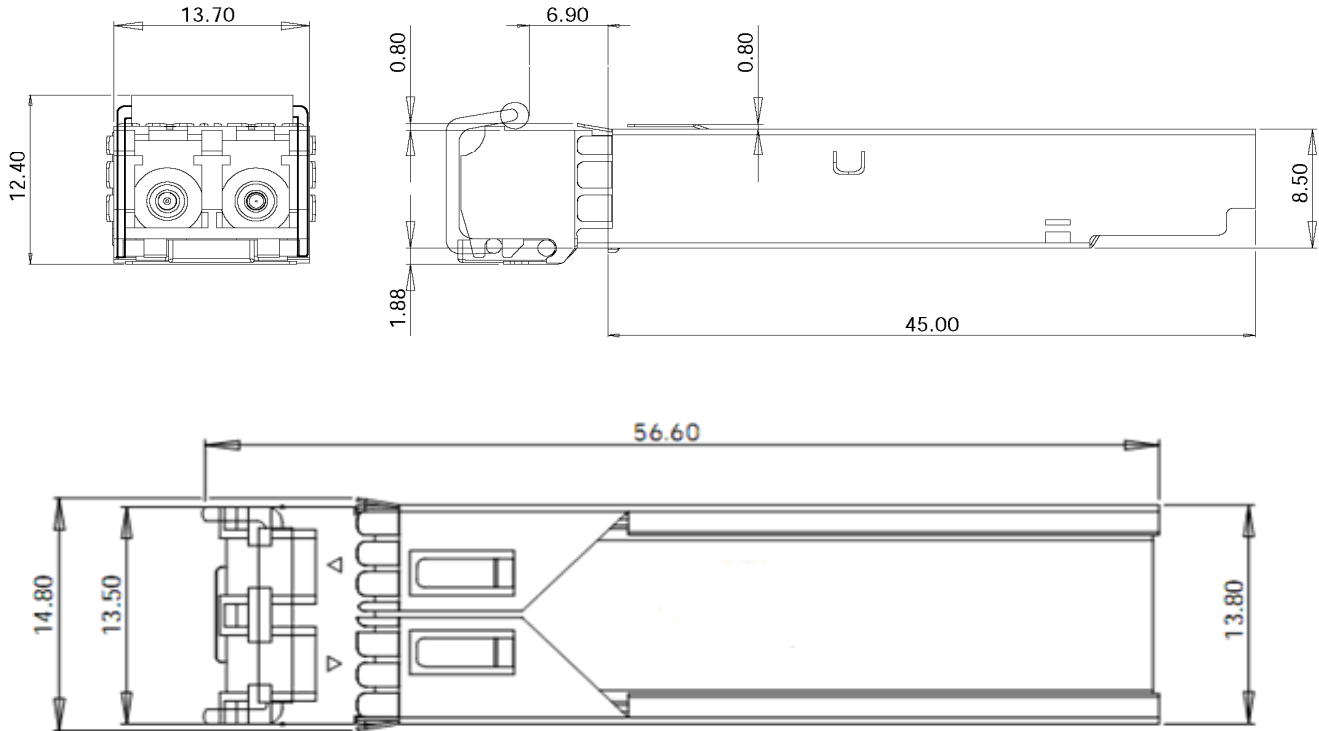

Diagnostics

Diagnostics Specification

Parameter	Range	Unit	Accuracy	Calibration
Temperature	0 to +70 -40 to +85	°C	±3°C	Internal/ External
Voltage	3.0 to 3.6	V	±3%	Internal/ External
Bias Current	2 to 15	mA	±10%	Internal/ External
TX Power	-8 to 3	dBm	±3dB	Internal/ External
RX Power	-21 to 0	dBm	±3dB	Internal/ External



*FH-S3125CDL20
2.5G SFP 1310nm LC 20km DDMI*

For More Information

FANG HANG TECH LIMITED

908 room, Jingyuan Building, 28 Bulong Rd, Longgang District, Shenzhen China

Tel: +86-755-89584520

Fax: +86-755-89584520

sales@fanghangtech.com

www.fanghangtech.com