

Product Features

- ✧ Support IEEE802.3 and Fiber Channel Applicable
- ✧ Support 1.25G GbE and 1.0625G for Fiber-Channel
- ✧ Support to 160km transmission on G.652 SMF
- ✧ 1550nm transmitter with DFB laser
- ✧ 1550nm receiver with APD-TIA
- ✧ 2-wire interface for integrated digital diagnostic monitoring
- ✧ SFP package with duplex LC/UPC receptacle optical interface
- ✧ Single +3.3V power supply
- ✧ RoHS6 Compliant
- ✧ Operating case temperature Commercial: 0°C to +70°C
Extended: -10°C to +80°C
Industrial: -40°C to +85°C



Applications

- ✧ Gigabit Ethernet
- ✧ Fiber Channel
- ✧ Switch to Switch interface
- ✧ Switched backplane applications
- ✧ Router/Server interface
- ✧ Other optical transmission systems

Ordering Information

Part Number	Output Power	Rec. Sens	Data Rate	Wavelength	Distance
<i>FH-S5512CDL160</i>	+3~ +7db	-34db	1.25/1.0625Gbps	1550nm	160KM
<i>FH-S5512EDL160</i>					
<i>FH-S5512IDL160</i>					

General

FH-S5512CDL160 SFP transceivers are high performance, cost effective modules supporting dual data-rate of 1.25Gbps/1.0625Gbps and 80km transmission distance with SMF.

The transceiver consists of three sections: a DFB laser transmitter, a APD photodiode integrated with a trans-impedance preamplifier (TIA) and MCU control unit. All modules satisfy class I laser safety requirements. Transceivers are compatible with SFP Multi-Source Agreement (MSA) and SFF-8472. For further information, please refer to SFP MSA

Absolute Maximum Ratings

Parameter	Symbol	Min.	Max.	Unit	Note
Supply Voltage	Vcc	-0.5	3.6	V	
Storage Temperature		-40	85	°C	
Relative Humidity		5	85	%	

Note: Stress in excess of the maximum absolute ratings can cause permanent damage to the module

General Operating Characteristics

Parameter	Symbol	Min.	Typ.	Max.	Unit	Notes
Data Rate	Gigabit Ethernet		1.25		Gb/s	
	Fiber Channel		1.0625			
Supply Voltage	Vcc	3.1	3.3	3.5	V	
Supply Current	Icc			300	mA	
Operating Case Temperature	Tc	0		70	°C	
		-10		80		
		-45		85		

Electrical Input/Output Characteristics

Parameter	Symbol	Min.	Typical	Max.	Unit	Notes
Transmitter						
Diff. Input Voltage Swing		200		2000	mVpp	1
Tx Disable Input	H	V_{IH}	2.0	$V_{CC}+0.3$	V	
	L	V_{IL}	0	0.8		
Tx Fault Output	H	V_{OH}	2.4	$V_{CC}+0.3$	V	2
	L	V_{OL}	0	0.4		
Input Diff. Impedance	Z_{in}	90	100	110	Ω	
Receiver						
Diff. Output Voltage Swing		400		1600	mVpp	3
Rx LOS Output	H	V_{OH}	2.0	$V_{CC}+0.3$	V	2
	L	V_{OL}	0	0.8		

Note: 1) TD+/- are internally AC coupled with 100 Ω differential termination inside the module.

2) Tx Fault and Rx LOS are open collector outputs, which should be pulled up with 4.7k to 10k Ω resistors on the host board. Pull up voltage between 2.0V and $V_{CC}+0.3V$.

3) RD+/- outputs are internally AC coupled, and should be terminated with 100 Ω (differential) at the user SERDES.

Optical Characteristics

Parameter	Symbol	Min.	Typical	Max.	Unit	Notes
Transmitter						
Ave. Output Power (Enable)	Po	+3		+7	dBm	1
Extinction Ratio	ER	9			dB	1
Rise/Fall Time (20%-80%)	Tr-Tf			0.26	ns	2
Wavelength Range		1500	1550	1580	nm	
Spectral Width (RMS)				1	nm	
Output Optical Eye	Compliant with IEEE802.3 z (class 1 user safety)					
Receiver						
Operating Wavelength		1260	1550	1610	nm	
Sensitivity	Pimin			-34	dBm	3
Min. Overload	Pimax	-3			dBm	3
LOS Assert	Pa	-40			dBm	
LOS De-assert	Pd			-35	dBm	
LOS Hysteresis	Pd-Pa	0.5		6	dB	

Note 1) Measured at 1250 Mb/s with PRBS 223 – 1 NRZ test pattern.

2) Unfiltered, measured with a PRBS 223-1 test pattern @1.25Gbps

3) Measured at 1250 Mb/s with PRBS 223 – 1 NRZ test pattern for BER < 1x10⁻¹²

Pin Definitions And Functions

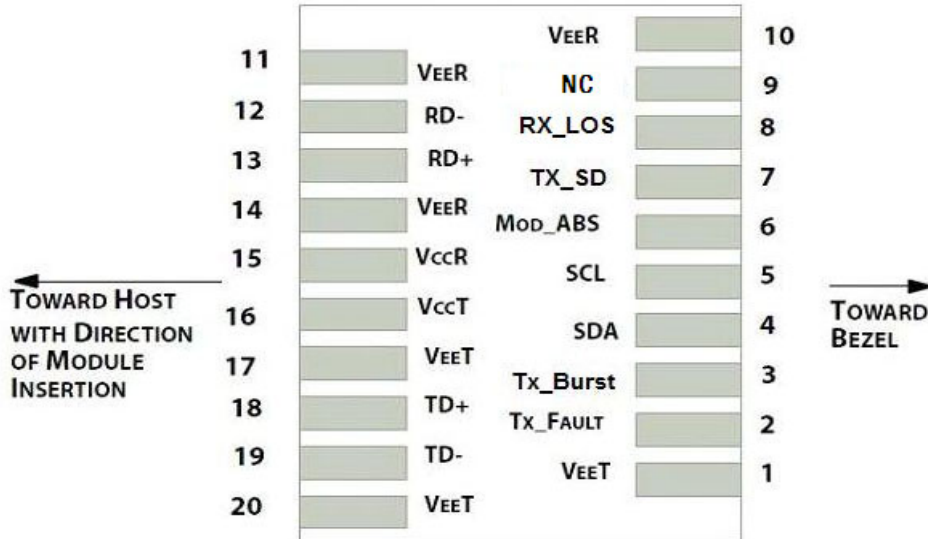

Pin No.	Symbol	Level / Logic	Description
1	VeeT		Module Transmitter Ground
2	Tx_Fault	LVTTL-O	Module Transmitter Fault Indication
3	Tx_DIS	LVTTL-I	Transmitter Disable; Active High Disable Transmitter Output
4	SDA	LVTTL-I	2-Wire Serial Interface Data Line
5	SCL	LVTTL-I/O	2-Wire Serial Interface Clock
6	MOD_ABS	LVTTL-O	Module Absent, connected to ground in the module
7	RS0		Not Connected
8	RX_LOS	LVTTL-O	Loss of Receiver Signal Indication
9	RS1		Not Connected
10	VeeR		Module Receiver Ground
11	VeeR		Module Receiver Ground
12	RD-	CML-O	Receiver Inverted Data Output
13	RD+	CML-O	Receiver Non-Inverted Data Output
14	VeeR		Module Receiver Ground
15	VccR		Module Receiver 3.3V Supply
16	VccT		Module Transmitter 3.3V Supply
17	VeeT		Module Transmitter Ground
18	TD+	CML-I	Transmitter Non-Inverted Data Input
19	TD-	CML-I	Transmitter Inverted Data Input
20	VeeT		Module Transmitter Ground

Recommended Interface Circuit

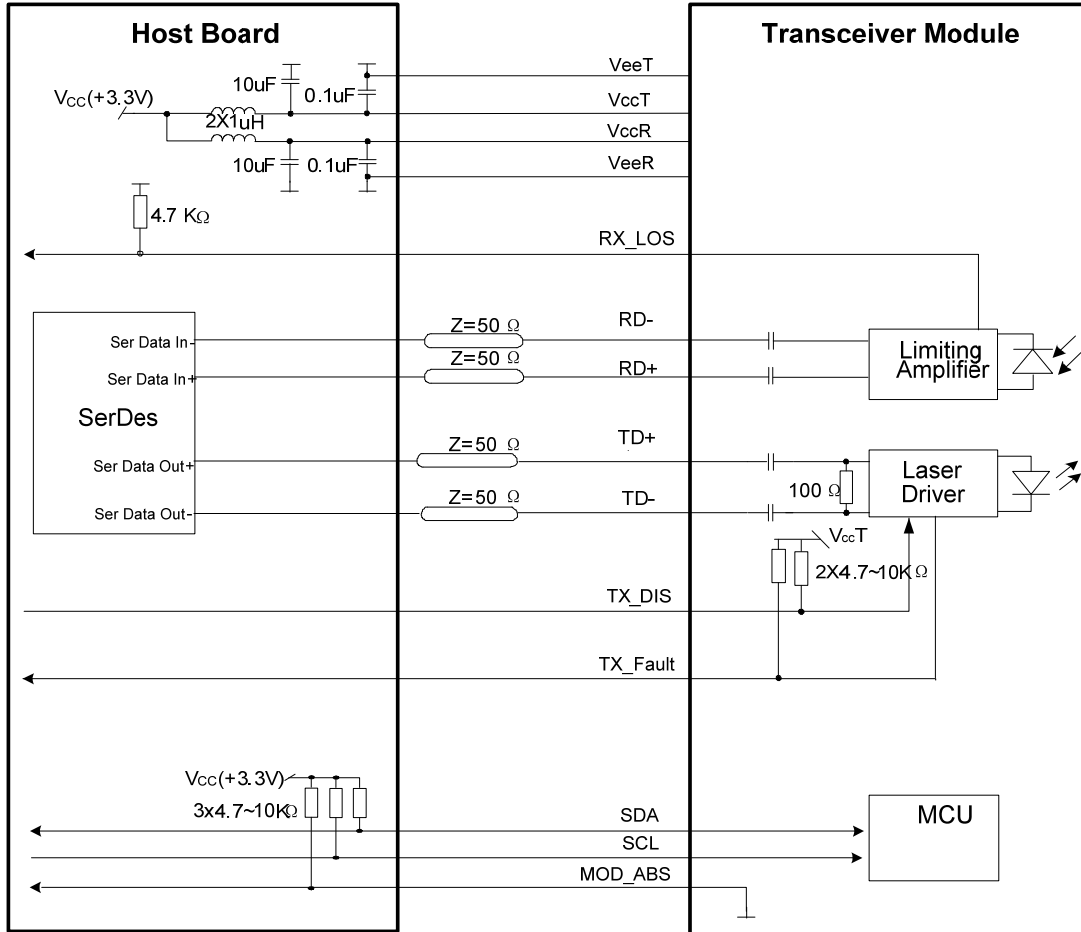

EEPROM Memory Map

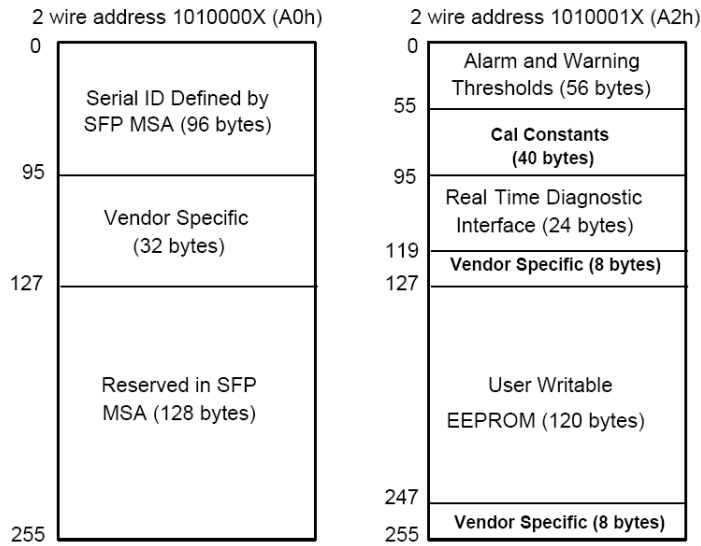

Package Dimensions

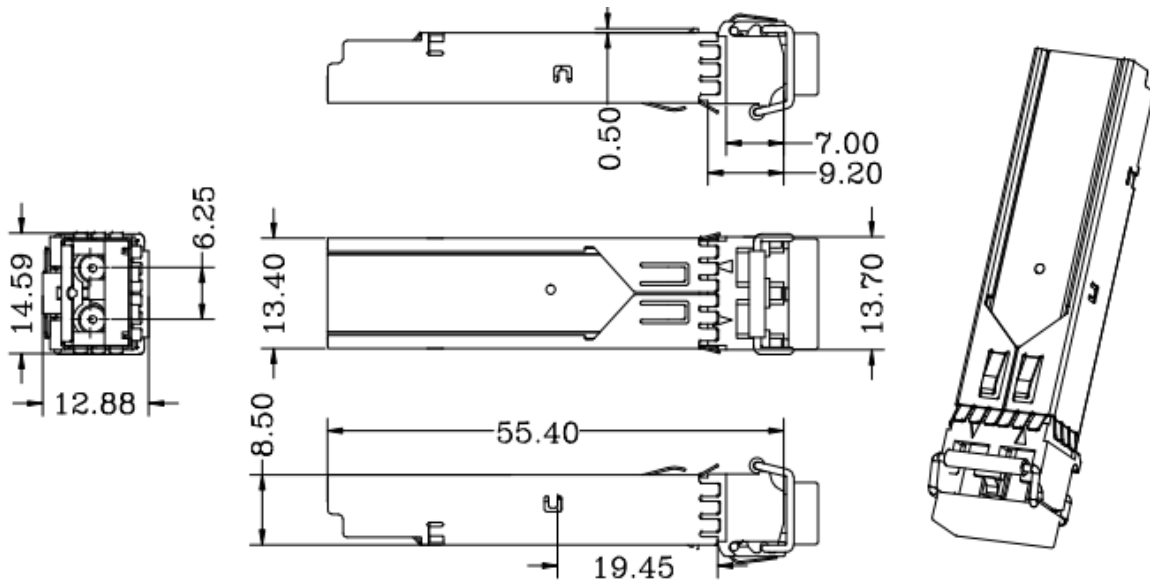



FH-S5512CDL160
1.25G SFP 1550nm LC 160km DDMI

For More Information

FANG HANG TECH LIMITED

Add: Room 908, Jingyuan Building, 28 Bulong Rd, Longgang District, Shenzhen China

Tel: +86-755-89584520

Fax: +86-755-89584520

sales@fanghangtech.com

www.fanghangtech.com