

Product Features

- ✧ Data-rate of 1.25Gbps operation
- ✧ CWDM DFB wavelengths laser and PIN photo-detector for 40km transmission
- ✧ Compliant with SFP MSA and SFF-8472 with duplex LC receptacle
Hot-pluggable SFP footprint
- ✧ Duplex LC/UPC type pluggable optical interface
- ✧ RoHS compliant and lead-free
- ✧ Single +3.3V power supply
- ✧ Compatible with SONET OC-24-LR-1
- ✧ Support Digital Diagnostic Monitoring interface
- ✧ Case operating temperature: 0°C to +70°C /-40°C to +85°C



Applications

- ✧ Gigabit Ethernet
- ✧ Fiber Channel
- ✧ Switch to Switch interface
- ✧ Switched Backplane Applications
- ✧ Router/Server Interface
- ✧ Other Optical Links

Ordering Information

Part Number	Output Power	Rec. Sens	Data Rate	Wavelength	Distance
FH-SCxx12CDL40	-6 ~ +1 db	-22db	1.25G	XX nm	40km

General

FH-SCxx12CDL40 SFP transceivers are high performance, cost effective modules supporting data-rate of 1.25Gbps and 40km transmission distance with SMF.

The transceiver consists of three sections: an uncooled CWDM DFB laser transmitter, a PIN photodiode integrated with a trans-impedance Pre-amplifier (TIA) and MCU control unit. All modules satisfy class I laser safety requirements.

The transceivers are compatible with SFP Multi-Source Agreement (MSA) and SFF-8472. For further information, please refer to SFP MSA..

Absolute Maximum Ratings

Parameter	Symbol	Min.	Max.	Unit	Note
Supply Voltage	Vcc	-0.5	4.0	V	
Storage Temperature		-40	85	°C	
Relative Humidity		5	85	%	

Note: Stress in excess of the maximum absolute ratings can cause permanent damage to the module

General Operating Characteristics

Parameter	Symbol	Min.	Typ	Max.	Unit	Note
Data Rate			1250		Gb/s	
Supply Voltage	Vcc	3.13	3.3	3.47	V	
Supply Current	Icc5			220	mA	
Operating Case Temp.	Tc	0		70	°C	

Electrical Input/Output Characteristics

Parameter	Symbol	Min.	Typ	Max.	Unit	Note
Transmitter						
Diff. input voltage swing		120		820	mVpp	1
Tx Disable input	H	VIH	2.0		Vcc+0.3	V
	L	VIL	0		0.8	
Tx Fault output	H	VOH	2.0		Vcc+0.3	V
	L	VOL	0		0.8	

Receiver						
Diff. output voltage swing		340	650	800	mVpp	3
Rx LOS Output	H	VOH	2.0		Vcc+0.3	V
	L	VOL	0		0.8	
Input Diff. Impedance	Zin		100		Ω	

Note 1) TD+/- are internally AC coupled with 100Ω differential termination inside the module.

Note 2) Tx Fault and Rx LOS are open collector outputs, which should be pulled up with 4.7k to 10kΩ resistors on the host board. Pull up voltage between 2.0V and Vcc+0.3V.

Note 3) RD+/- outputs are internally AC coupled, and should be terminated with 100Ω (differential) at the user SERDES.

Optical Characteristics

Parameter	Symbol	Min.	Typ	Max.	Unit	Note
Transmitter						
Operating Wavelength	λ_C		xx		nm	3
Ave. output power (Enabled)	P_o	-6		+1	dBm	1
Extinction Ratio	ER	9			dB	1
RMS spectral width	$\Delta\lambda$			4	nm	
Rise/Fall time (20%~80%)	T_r/T_f			0.26	ps	2
Output Eye Mask	Compliant with IEEE802.3 z (class 1 laser safety)					
Receiver						
Operating Wavelength		1270		1610	nm	
Sensitivity	P_{sen}			-22	dBm	4
Min. overload	P_{imax}	-3			dBm	
LOS Assert	P_a	-40			dBm	
LOS De-assert	P_d			-23	dBm	5
LOS Hysteresis	P_d-P_a	0.5		6	dB	

- Note
- 1 Measure at 2⁷-1 NRZ PRBS pattern
 - 2 Transmitter eye mask definition
 - 3 "XX" is:27,29,31,33,35,37,39,41,43,45,47,49,51,53,55,57,59 and 61; " $\Delta\lambda$ " is 7.5
 - 4 Measured with Light source 1XX0 nm, ER=9dB; BER =<10⁻¹² @PRBS=2⁷-1 NRZ
 - 5 When LOS de-asserted, the RX data+/- output is High-level (fixed)

Pin Definitions And Functions

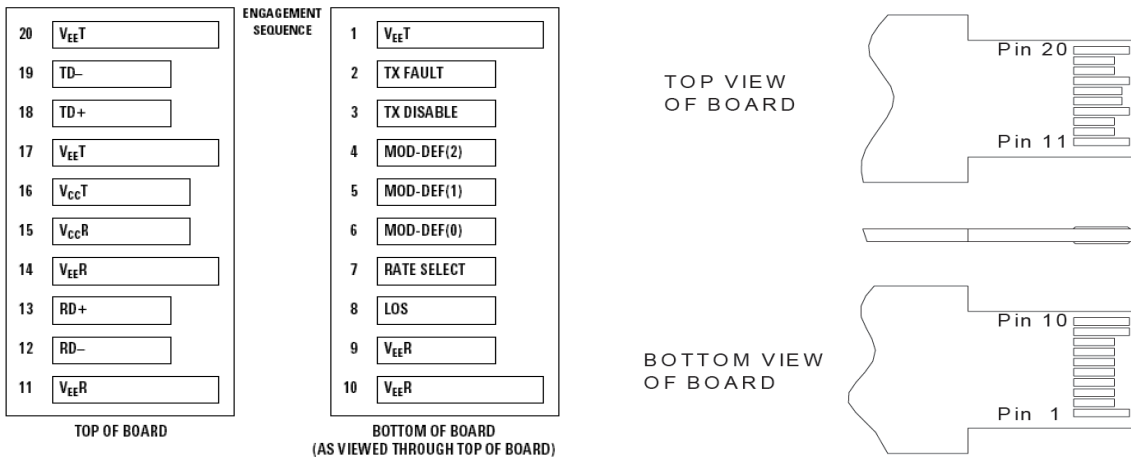

PIN #	Name	Function	Notes
1	VeeT	Tx ground	
2	Tx Fault	Tx fault indication, Open Collector Output, active "H"	Note 1
3	Tx Disable	LVTTL Input, internal pull-up, Tx disabled on "H"	Note 2
4	MOD-DEF2	2 wire serial interface data input/output (SDA)	Note 3
5	MOD-DEF1	2 wire serial interface clock input (SCL)	Note 3
6	MOD-DEF0	Model present indication	Note 3
7	Rate select	No connection	
8	LOS	Rx loss of signal, Open Collector Output, active "H"	Note 4
9	VeeR	Rx ground	
10	VeeR	Rx ground	
11	VeeR	Rx ground	
12	RD-	Inverse received data out	Note 5
13	RD+	Received data out	Note 5
14	VeeR	Rx ground	
15	VccR	Rx power supply	
16	VccT	Tx power supply	
17	VeeT	Tx ground	
18	TD+	Transmit data in	Note 6
19	TD-	Inverse transmit data in	Note 6
20	VeeT	Tx ground	

- Notes: 1) When high, this output indicates a laser fault of some kind. Low indicates normal operation. And should be pulled up with a 4.7 – 10KΩ resistor on the host board.
- 2) TX disable is an input that is used to shut down the transmitter optical output. It is pulled up within the module with a 4.7 – 10KΩ resistor. Its states are:
 Low (0 – 0.8V): Transmitter on (>0.8, < 2.0V): Undefined
 High (2.0V~Vcc+0.3V): Transmitter Disabled Open: Transmitter Disabled
- 3) Mod-Def 0,1,2. These are the module definition PINs. They should be pulled up with a 4.7K – 10KΩ resistor on the host board. The pull-up voltage shall be between 2.0V~Vcc+0.3V.
 Mod-Def 0 has been grounded by the module to indicate that the module is present
 Mod-Def 1 is the clock line of two wire serial interface for serial ID
 Mod-Def 2 is the data line of two wire serial interface for serial ID
- 4) When high, this output indicates loss of signal (LOS). Low indicates normal operation.
- 5) RD+/-: These are the differential receiver outputs. They are AC coupled 100Ω differential lines which should be terminated with 100Ω (differential) at the user SERDES. The AC coupling is done inside the module and is thus not required on the host board.
- 6) TD+/-: These are the differential transmitter inputs. They are AC-coupled, differential lines with 100Ω differential termination inside the module. The AC coupling is done inside the module and is thus not required on the host board.

Diagnostics

Parameter	Range	Unit	Accuracy	Calibration
Temperature	0 to +70 -40 to +85	°C	±3°C	Internal/ External
Voltage	3.0 to 3.6	V	±3%	Internal/ External
Bias Current	2 to 80	mA	±10%	Internal/ External
TX Power	+7 to +2	dBm	±3dB	Internal/ External
RX Power	-29 to 0	dBm	±3dB	Internal/ External

Functional Diagram

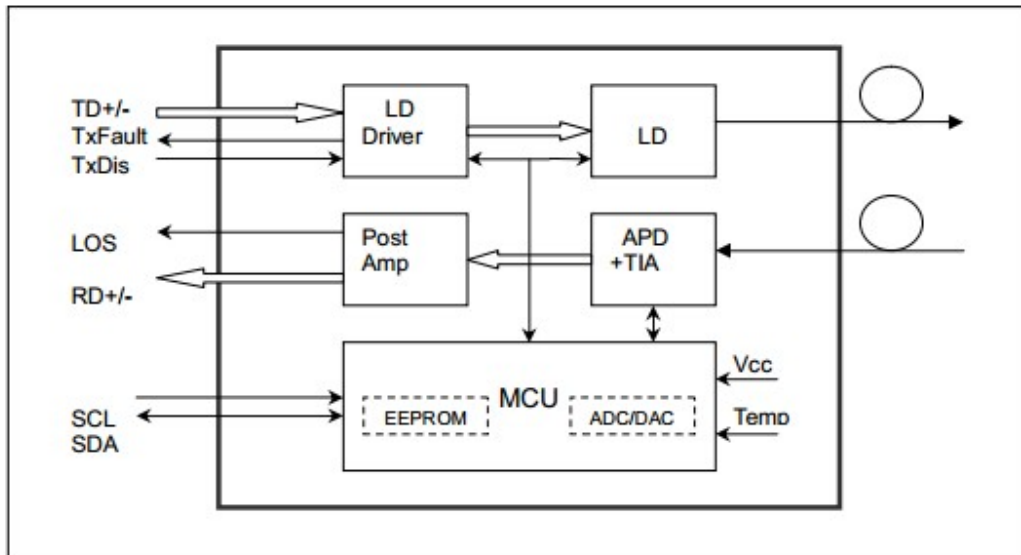

Product Selection

Wavelength	XX	Clasp Color Code	Wavelength	XX	Clasp Color Code
1270nm	27	Gray	1450nm	45	Brown
1290nm	29	Gray	1470nm	47	Gray
1310nm	31	Gray	1490nm	49	Purple
1330nm	33	Purple	1510nm	51	Blue
1350nm	35	Blue	1530nm	53	Green
1370nm	37	Green	1550nm	55	Yellow
1390nm	39	Yellow	1570nm	57	Orange
1410nm	41	Orange	1590nm	59	Red
1430nm	43	Red	1610nm	61	Brown

Typical Interface Circuit

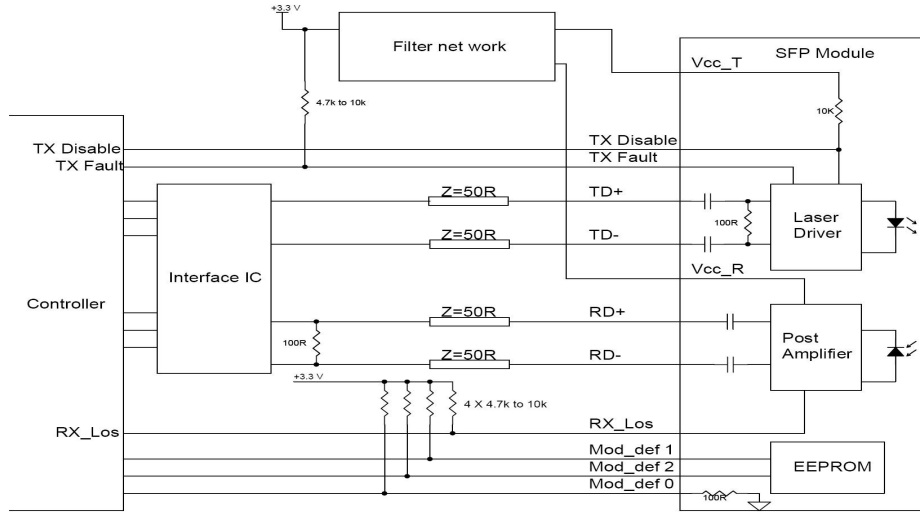

Package Dimensions

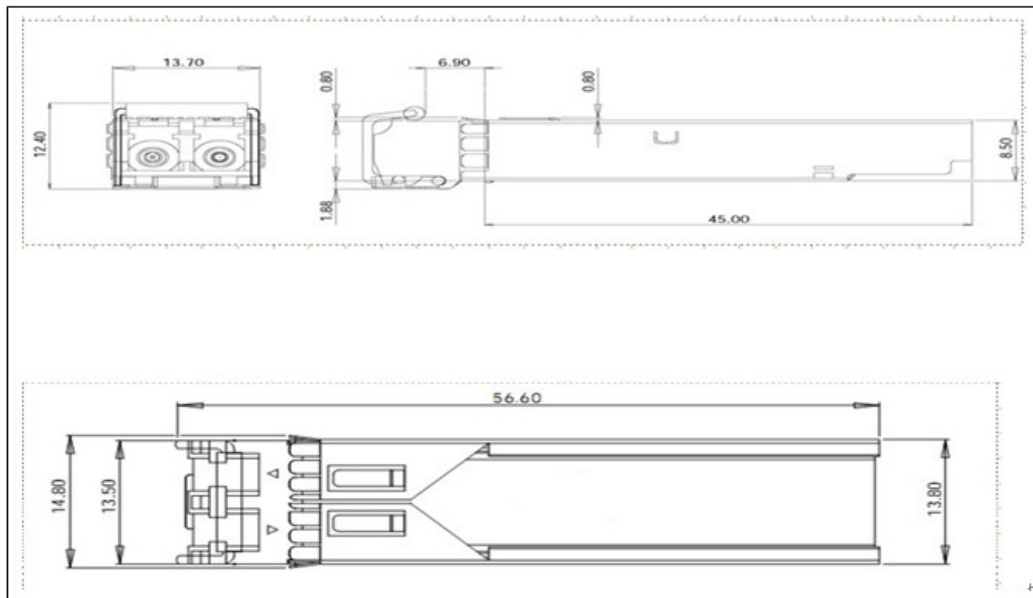



FH-SCxx12CDL40
1.25G SFP CWDM XX nm 40km LC DDMI

For More Information

FANG HANG TECH LIMITED

Add: Room 908 Jing yuan Building, Bu long Rd, Long gang District, Shen zhen China

Tel: +86-755-89584520

Fax: +86-755-89584520

sales@fanghangtech.com

www.fanghangtech.com