

Product Features

- ✧ Up to 1250Mbps data links
- ✧ DWDM EML laser transmitter and APD photo-detector
- ✧ 100 GHz ITU channel spacing with integrated wavelength locker
- ✧ Up to 80km on 9/125μm SMF
- ✧ Hot-pluggable SFP footprint
- ✧ Metal enclosure, for lower EMI
- ✧ Duplex LC/UPC type pluggable optical interface
- ✧ RoHS compliant and lead-free
- ✧ Single +3.3V power supply
- ✧ Compliant with SFF-8472
- ✧ Low power dissipation
- ✧ Support Digital Diagnostic Monitoring interface
- ✧ Case operating temperature: 0°C to +70°C



Applications

- ✧ C-Band DWDM networks
- ✧ Fiber Channel
- ✧ SONET/SDH networks
- ✧ Gigabit Ethernet

Ordering Information

Part Number	Output Power	Rec. Sens	Data Rate	Wavelength	Distance
FH-SDxx15CDL80	0~ +4dBm	-26dBm	1.25G	xxnm	80km

Wavelength Selection: C-band λ_c Wavelength Guide Pin Descriptions

Channel	Wavelength (nm)	Frequency (THZ)	Channel	Wavelength (nm)	Frequency (THZ)
C17	1563.86	191.70	C39	1546.12	193.90
C18	1563.05	191.80	C40	1545.32	194.00
C19	1562.23	191.90	C41	1544.53	194.10
C20	1561.42	192.00	C42	1543.73	194.20
C21	1560.61	192.10	C43	1542.94	194.30
C22	1559.79	192.20	C44	1542.14	194.40
C23	1558.98	192.30	C45	1541.35	194.50
C24	1558.17	192.40	C46	1540.56	194.60
C25	1557.36	192.50	C47	1539.77	194.70
C26	1556.55	192.60	C48	1538.98	194.80
C27	1555.75	192.70	C49	1538.19	194.90
C28	1554.94	192.80	C50	1537.40	195.00
C29	1554.13	192.90	C51	1536.61	195.10
C30	1553.33	193.00	C52	1535.82	195.20
C31	1552.52	193.10	C53	1535.04	195.30
C32	1551.72	193.20	C54	1534.25	195.40
C33	1550.92	193.30	C55	1533.47	195.50
C34	1550.12	193.40	C56	1532.68	195.60
C35	1549.32	193.50	C57	1531.90	195.70

C36	1548.51	193.60	C58	1531.12	195.80
C37	1547.72	193.70	C59	1530.33	195.90
C38	1546.92	193.80	C60	1529.55	196.00
Non-ITU	Peak wavelength between 1528.77nm-1563.86		C61	1528.77	196.10

General

FH-SDxx12CDL80 transceivers include an APD photo-detector diode and temperature stabilized DWDM EML transmitter. Digital diagnostic functions are available via an I2C. This module is designed for single mode fiber and operates at a nominal wavelength of 100GHz ITU Grid, C Band DWDM wavelength. Digital diagnostics functions are available via a 2-wire serial interface, as specified in SFF8472.

The optical output can be disabled by a TTL logic high-level input of Tx Disable, and the system also can disable the module via I2C. Tx Fault is provided to indicate that degradation of the laser. Loss of signal (LOS) output is provided to indicate the loss of an input optical signal of receiver or the link status with partner. The system can also get the LOS (or Link)/Disable/Fault information via I2C register access.

Absolute Maximum Ratings

Parameter	Symbol	Min.	Max.	Unit	Note
Supply Voltage	Vcc	-0.5	3.6	V	
Storage Temperature		-40	85	°C	
Relative Humidity		5	95	%	

Note: Stress in excess of the maximum absolute ratings can cause permanent damage to the module

General Operating Characteristics

Parameter	Symbol	Min.	Typ	Max.	Unit	Note
Data Rate			1250		Mb/s	
Supply Voltage	Vcc	3.13	3.3	3.47	V	
Supply Current	Icc			220	mA	
Operating Case Temp.	Tc	0		70	°C	

Electrical Input/Output Characteristics

Parameter	Symbol	Min.	Typical	Max.	Unit	Notes
Transmitter						
Diff. input voltage swing		200		2400	mVpp	1
Tx Disable input	H	VIH	2.0	Vcc+0.3	V	
	L	VIL	0	0.8		
Tx Fault output	H	VOH	2.0	Vcc+0.3	V	2
	L	VOL	0	0.8		
Input Diff. Impedance	Zin	90	100	110	Ω	
Receiver						
Diff. output voltage swing		500		900	mVpp	3
Rx LOS Output	H	VOH	2.0	Vcc+0.3	V	2
	L	VOL	0	0.8		

Note 1) AC-Coupled CML logic family.

Note 2) Tx Fault and Rx LOS are open collector outputs, which should be pulled up with 4.7k to 10kΩ resistors on the host board. Pull up voltage between 2.0V and Vcc+0.3V.

Note 3) RD+/- outputs are internally AC coupled, and should be terminated with 100Ω (differential) at the user SERDES.

Optical Characteristics

Parameter	Symbol	Min.	Typ	Max.	Unit	Note
Transmitter						
Operating Wavelength			xx		nm	3
Ave. output power (Enabled)	Po	0		+4	dBm	1
Extinction Ratio	ER	9			dB	1
Side Mode Suppression Ratio	SMSR	30			dB	
RMS spectral width	$\Delta\lambda$			1	nm	
Rise/Fall Time (20%-80%)	Tr-Tf			0.26	ns	2
Output Optical Eye	Compliant with 802.3z(class 1 laser safety)					
Receiver						
Operating Wavelength		1270		1610	nm	
Sensitivity	Psen			-26	dBm	4
Min. overload	Pimax	-10			dBm	
LOS Assert	Pa	-41			dBm	
LOS De-assert	Pd			-31	dBm	5
LOS Hysteresis	Pd-Pa	0.5	2	6	dB	

The following optical characteristics are defined over the Recommended Operating Environment unless otherwise specified.

Notes:

1. λc refer to wavelength selection, and corresponds to approximately 0.8 nm
2. Measure at 2⁷-1 NRZ PRBS pattern
3. Measured with Light source 1563.86~1528.77nm, ER=9dB; BER =<10⁻¹² @PRBS=2⁷-1 NRZ
4. When LOS de-asserted, the RX data+/- output is High-level (fixed).

Pin Definitions And Functions

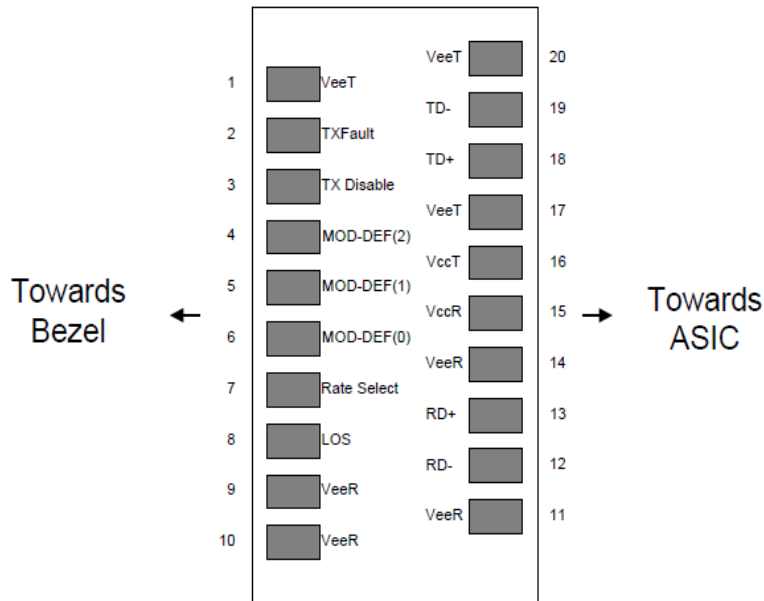

PIN	Name	Name/Description	Notes
1	VEET	Transmitter Ground (Common with Receiver Ground)	1
2	TXFAULT	Transmitter Fault.	
3	TXDIS	Transmitter Disable. Laser output disabled on high or open.	2
4	MOD_DEF(2)	Module Definition 2. Data line for Serial ID.	3
5	MOD_DEF(1)	Module Definition 1. Clock line for Serial ID.	3
6	MOD_DEF(0)	Module Definition 0. Grounded within the module.	3
7	Rate Select	No connection required	4
8	LOS	Loss of Signal indication. Logic 0 indicates normal operation.	5
9	VEER	Receiver Ground (Common with Transmitter Ground)	1
10	VEER	Receiver Ground (Common with Transmitter Ground)	1
11	VEER	Receiver Ground (Common with Transmitter Ground)	1

12	RD-	Receiver Inverted DATA out. AC Coupled	
13	RD+	Receiver Non-inverted DATA out. AC Coupled	
14	VEER	Receiver Ground (Common with Transmitter Ground)	1
15	VCCR	Receiver Power Supply	
16	VCCT	Transmitter Power Supply	
17	VEET	Transmitter Ground (Common with Receiver Ground)	1
18	TD+	Transmitter Non-Inverted DATA in. AC Coupled.	
19	TD-	Transmitter Inverted DATA in. AC Coupled.	
20	VEET	Transmitter Ground (Common with Receiver Ground)	1

Notes:

1. Circuit ground is internally isolated from chassis ground.
2. Laser output disabled on TDIS >2.0V or open, enabled on TDIS <0.8V.
3. Should be pulled up with 4.7k - 10kohms on host board to a voltage between 2.0V and 3.6V. MOD_DEF (0) pulls line low to indicate module is plugged in.
4. This is an optional input used to control the receiver bandwidth for compatibility with multiple data rates (most likely Fiber Channel 1x and 2x Rates). If implemented, the input will be internally pulled down with > 30kΩ resistor. The input states are:
 - 1) Low (0 – 0.8V): Reduced Bandwidth
 - 2) (>0.8, < 2.0V): Undefined
 - 3) High (2.0 – 3.465V): Full Bandwidth
 - 4) Open: Reduced Bandwidth
5. LOS is open collector output should be pulled up with 4.7k - 10kohms on host board to a voltage between 2.0V and 3.6V. Logic 0 indicates normal operation; logic 1 indicates loss of signal.

Package Dimensions

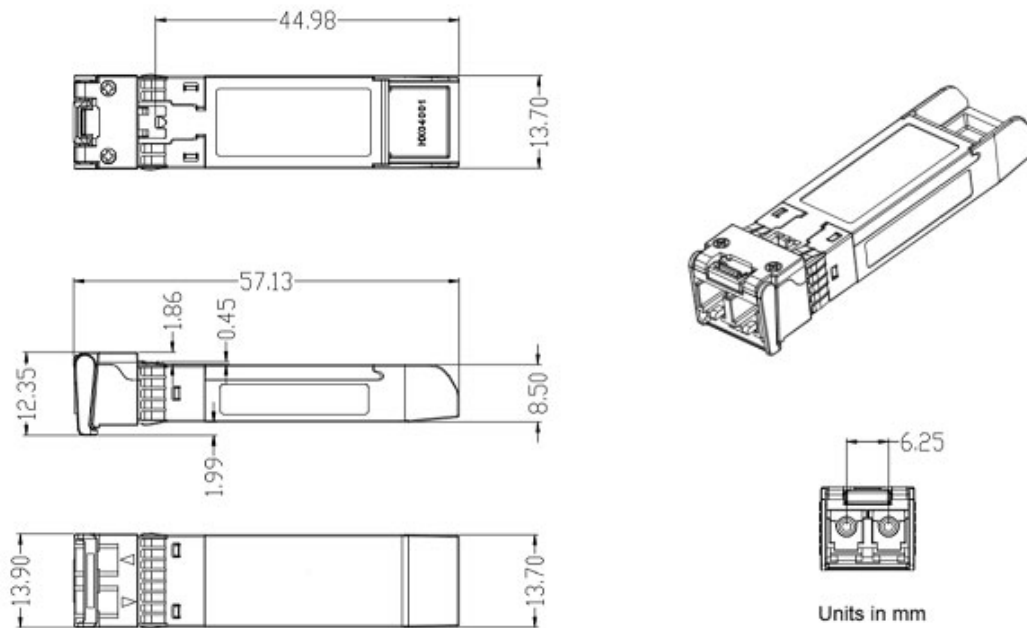

Diagnostics

Diagnostics Specification

Parameter	Range	Unit	Accuracy	Calibration
Temperature	0 to +70 -40 to +85	°C	±3°C	Internal/ External
Voltage	3.0 to 3.6	V	±3%	Internal/ External
Bias Current	2 to 80	mA	±10%	Internal/ External
TX Power	-3 to 5	dBm	±3dB	Internal/ External
RX Power	-26 to 0	dBm	±3dB	Internal/ External



*FH-SDxx12CDL80
1.25G SFP DWDM xxnm LC 80km DDMI*

For More Information

FANG HANG TECH LIMITED

908 room, Jingyuan Building, 28 Bulong Rd, Longgang District, Shenzhen China

Tel: +86-755-89584520

Fax: +86-755-89584520

sales@fanghangtech.com

www.fanghangtech.com