

Product Features

- ✧ 24.33Gb/s to 25.78Gb/s data links with Single mode operation
- ✧ High performance 1270 nm DML laser
- ✧ High sensitivity APD/TIA optical receiver
- ✧ 2x10 SFP+ MSA compliant package with LC Bi-direction optic interface
- ✧ Compliant with SFP MSA and SFF-8472 with duplex LC receptacle
- ✧ Maximum link length of 40km
- ✧ Low DC Power consumption
- ✧ +3.3V single power supply
- ✧ BER < 5X10⁻⁵ with Built-in CDR
- ✧ RoHS compliant
- ✧ Data and Control Interfaces:
 - ✧ Tx Data CML/AC Coupled
 - ✧ Rx Data CML/AC Coupled
 - ✧ Tx_DIS LVTTTL
 - ✧ Tx_FAULT LVTTTL
 - ✧ Rx_LOS LVTTTL
 - ✧ MOD_ABS LVTTTL
- ✧ 2-wire I2C data bus
- ✧ Temperature range: Industrial: -40°C to +85°C



Applications

- ✧ 25G BASE-ER Ethernet
- ✧ CPRI 25G
- ✧ OUT-4

Ordering Information

Part Number	Output Power	Rec. Sens	Data Rate	Wavelength	Distance
FH-SPB232TCDL40	0~+6dBm	-19dBm	25G	1270/1330	40KM

General

FH-SPB232TCDL40 footprint transceiver is intended for 40km reach service from 24.33Gb/s to 25.78Gb/s Tx1270nm/Rx1330 single mode high-speed communications equipment where low-cost, extraordinary performance and reliability are essential. It consumes low power, operates base on 3.3V DC power supply and is offered in the Industrial temperature range. They are compliant with SFP28 MSA , SFF-8431 and SFF-8432. The low jitter and low bit error rate optical assembly features a 1270nm DML laser transmitter and APD/TIA receiver. It incorporates the SFP+ MSA LVTTTL Loss of Signal (Rx_LOS), Tx Fault (Tx_FAULT), MOD_ABS and Tx Disable (Tx_DIS) monitor and control functions . It utilizes internal clock and data recovery (CDR) units on transmitter and the receiver chains for low jitter compliance. The differential AC coupled Tx and Rx data interfaces are CML compatible. The device is Class I laser safety compliant.

Absolute Maximum Ratings (EXCEEDING THESE RATINGS MAY CAUSE IRREVERSIBLE DAMAGE TO THE DEVICE)					
Parameter	Symbol	Min	Max	Units	Notes
Storage Temperature	T _{stg}	-40	+95	°C	Exceeding the Absolute Maximum Ratings may cause irreversible damage to the device. The device is not intended to be operated under the condition of simultaneous Absolute Maximum Ratings, a condition which may cause irreversible damage to the device.
Case Operating Temperature (Industrial)	T _o	-40	+85	°C	
Relative Humidity - Storage	RH _s	0	95	%	
Relative Humidity - Operating	RH _o	0	85	%	
DC Supply Voltage	V _{CC}	0	3.6	V	

Recommended Operating Conditions						
Parameter	Symbol	Min	Typ	Max	Units	Notes
Case Operating Temperature	T _{case}	-40	-	85	°C	
DC Supply Voltage	V _{CC}	3.135	-	3.465	V	
Total Power Consumption	P	-	-	1.5	W	
ESD	-	1000			V	

Transmitter Electrical Characteristics						
Parameter	Symbol	Min	Typ	Max	Units	Notes
Differential Data input Swing	V _{IN}	200	-	800	mV	
Tx Differential Input Impedence	Z _{IN}	-	100	-	Ω	
Transmitter Disable Voltage	V _D	2.0	-	V _{CC} +0.3	V	
Transmitter Enable Voltage	V _{EN}	0	-	0.8	V	

Receiver Electrical Characteristics						
Parameter	Symbol	Min	Typ	Max	Units	Notes
Differential Data Output Swing	V_{OUT}	200	600	800	mV	
Rx Differential Output Impedance	Z_{OUT}	-	100	-	Ω	
LOS Assert Voltage	V_{LOSA}	2.4	-	V_{CC}	V	
LOS De-assert Voltage	V_{LOSD}	V_{EE}	-	$V_{EE}+0.4$	V	

Transmitter Optical Specification						
Parameter	Symbol	Min	Typ	Max	Units	Notes
Transmitter Laser Type		1270nm DML				
Optical Modulation Amplitude (OMA)	P_{OMA}	-1	-		dBm	
Average Output Power (EOL)	P_{OUT}	0	-	6	dBm	
Transmitter eye mask margin		5			%	NRZ 25G RATIO {x1:0.31,x2:0.4,x3:0.45, y1:0.34,y2:0.38,y3:0.4}; 500Waveform; 5E-5
Average Output Power (Laser Off)	P_{OFF}	-	-	-30	dBm	
Wavelength	λ	1260	-	1280	nm	
Spectral Line RMS Width @ -20dB	$\Delta\lambda$	-	-	1	nm	
Side Mode Suppression Mode	SMSR	30	-	-	dB	
Extinction ratio	ER	3	-	-	dB	
Dispersion Penalty	DP	-	-	3.5	dB	-40~85°C
Transmitter Reflectance (max)	TFL			-12	dB	

Receiver Optical Specifications						
Parameter	Symbol	Min	Typ	Max	Units	Conditions / Notes
Receiver Type		APD/TIA				
Wavelength	λ	1320	-	1340	nm	
Received Sensitivity (OMA)	$P_{IN}(OMA)$	-	-	-19	dBm	BER<5E-5, PRBS 2 ³¹ -1
Optical Power Overload	$P_{IN}(SAT)$	-7	-	-	dBm	BER<5E-5, PRBS 2 ³¹ -1
Rx_LOS of Signal Assert	P_A	-30	-	-	dBm	
Rx_LOS of Signal De-assert	P_D	-	-	-19	dBm	
Rx_LOS of Signal Hysteresis	P_{Hy}	0.5	-	5	dB	

I ² C Memory Map (Page A0 HEX, Unlisted Fields are Blank / Empty)				
IIC Addr	Size	Name	Description	Values (HEX)
0	1	Identifier	SFP	03
1	1	Extended Identifier	Extended Identifier	04
2	1	Connector	Connector Type = LC	07
3-10	8	Transceiver	25G Base ER	80 00 00 00 00 00 00 00
11	1	Encoding	Encoding Type = Manchester	03
12	1	BR, Nominal	Nominal Bit Rate 25.78Gb/s	FF
13	1	Reserved	Reserved	0D
14	1	Length(9μm)-km	40km Link Length in Kilometers / SMF	28
15	1	Length (9μm)-100m	40km Link Length in Hundreds of Meters / SMF	FF
16	1	Length (50μm)-10m	50-micron MMF Link Length = N/A	00
17	1	Length (62.5μm)-10m	62.5-micron MMF Link Length = N/A	00
18	1	Length (Copper)	Copper Link Length = N/A	00
19	1	Reserved	Reserved	00
20-35	16	Vendor name	Hisense	ASCII Format
36	1	Transceiver	25G/100G-ER4	04
37-39	3	Vendor OUI	SFP Vendor IEEE Company ID	AC 4A FE
40-55	16	Vendor PN	LTF2327-BH+	ASCII Format
56-59	4	Vendor Revision Number	Programmed by Factory	Programmed by Factory
60-61	2	Wavelength	Laser Wavelength = 1270nm	04 F6
62	1	Reserved	Reserved	00
63	1	CC_BASE	Check sum of bytes 0-62	Programmed by Factory
64-65	2	Transceiver Options	1. Internal CDR 2. Rx_LOS 3. Tx_FAULT 4. Tx_DIS	08 3A
66	1	BR, max	103% for 25.78G	67
67	1	BR, min	Unspecified	00
68-83	16	Vendor SN	Programmed by Factory	Programmed by Factory
84-91	8	Date code	Year,Month,Day	Programmed by Factory
92	1	Monitoring Type	Internally Calibrated Received power measurement type-Average Power	68
93	1	Enhanced Options	1. Optional Alarm/Warning Flags Implemented 2. Soft Tx_DIS Monitor and Contorl 3. Soft Rx_LOS Monitor 4. Soft Tx_FAULT Monitor	F8
94	1	Compliance	Revision implemented	08
95	1	CC_EXT	Check sum of bytes 64-94	Programmed by Factory
96-127	32	Vendor Specific	Vendor Specific EEPROM	Programmed by Factory
128-255	128	Vendor Specific	Vendor Specific	Programmed by Factory

A2 (hex) Table - Summary of Parameters in the A2 (hex) Parametric Table

The data in the parameter tables are compared with the data in the measured data tables in order to create a warning or alarm status bit. The Warning or Alarm bit is set when the parameter drops below or exceeds the Low or High values stored in memory.

A2 (HEX) Address Table for Alarm and Warning Data														
Parameter	Alarm Threshold Data				Warning Threshold Data				Measured Values		Alarm Bit (Set) Address + Position		Warning Bit (Set) Address + Position	
	High Value		Low Value		High Value		Low Value				High	Low	High	Low
	MSB	LSB	MSB	LSB	MSB	LSB	MSB	LSB	MSB	LSB				
Temperature	00	01	02	03	04	05	06	07	96	97	112 (7)	112 (6)	116 (7)	116 (6)
Vcc	08	09	10	11	12	13	14	15	98	99	112 (5)	112 (4)	116 (5)	116 (4)
Tx Bias	16	17	18	19	20	21	22	23	100	101	112 (3)	112 (2)	116 (3)	116 (2)
Tx Output	24	25	26	27	28	29	30	31	102	103	112 (1)	112 (0)	116 (1)	116 (0)
Rx Input	32	33	34	35	36	37	38	39	104	105	113 (7)	113 (6)	117 (7)	117 (6)

Internal CDR's Locking Modes

The FH-SPB232TCDL40 is equipped with internal clock and data recovery (CDR) units on both the receiver and the transmitter sides. Both CDR are locking between 24.33 and 25.78Gb/s by default,

And it will disregard the status of the rate select (RS0/RS1) pins. If any request for different CDR locking modes, please contact Hisense for additional information.

PIN Assignment

TOP VIEW
OF BOARD

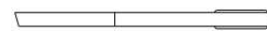
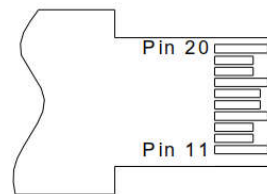

BOTTOM VIEW
OF BOARD

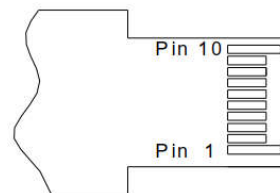

PIN Description			
PI N	Symbol	Name/Description	Note
1	V _{EET}	Transmitter Ground	
2	T _{FAULT}	Transmitter Fault.	1
3	T _{DIS}	Transmitter Disable. Laser output disabled on high.	
4	SDA	2-wire Serial Interface Data Line (MOD-DEF2)	
5	SCL	2-wire Serial Interface Clock (MOD-DEF1)	
6	MOD_ABS	Module Absent, connected to V _{EET}	
7	RS0	Rx Rate Select: NOT implement	2
8	Rx_LOS	Loss of Signal indication. Logic 0 indicates normal operation.	1
9	RS1	Tx Rate Select: NOT implement	2
10	V _{EER}	Receiver Ground	
11	V _{EER}	Receiver Ground	
12	RD-	Receiver Inverted DATA out.	3
13	RD+	Receiver Non-inverted DATA out.	3
14	V _{EER}	Receiver Ground	
15	V _{CCR}	Receiver Power Supply	
16	V _{CCT}	Transmitter Power Supply	
17	V _{EET}	Transmitter Ground	
18	TD+	Transmitter Non-Inverted DATA in.	4
19	TD-	Transmitter Inverted DATA in.	4
20	V _{EET}	Transmitter Ground	
Notes			
<ol style="list-style-type: none"> 1. Shall be pulled up with 4.7k-10k ohms to a voltage between 3.15V and 3.6V on the host board. 2. The pins are pulled low to V_{EET} with a >30k resistor in the module. 3. The 100Ohms differential Rx Data output is internally AC coupled and terminated. 4. The 100Ohms differential Tx Data input is internally AC coupled and terminated. 			

Electrical Interface

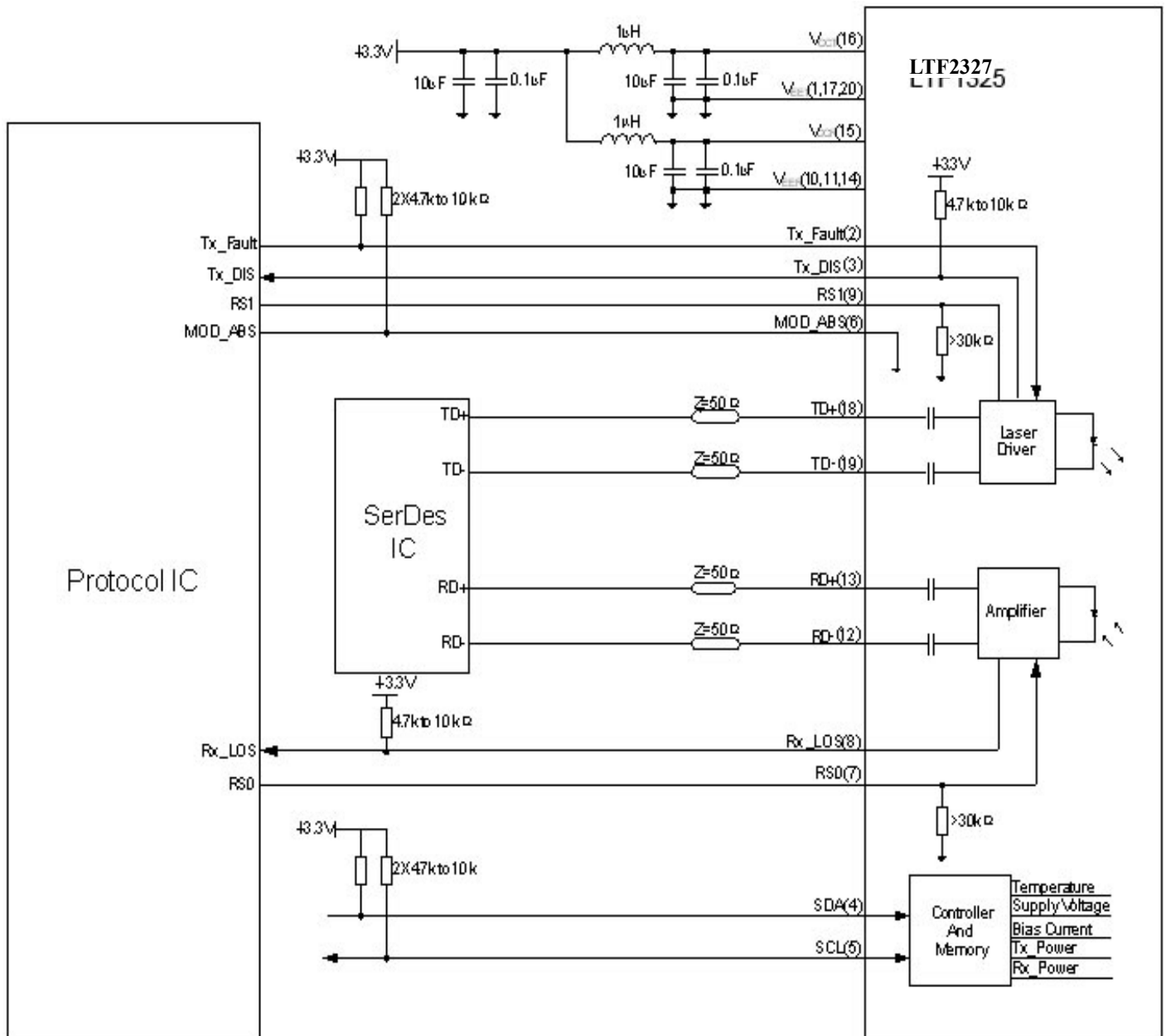

RECOMMENDED PCB LAYOUT

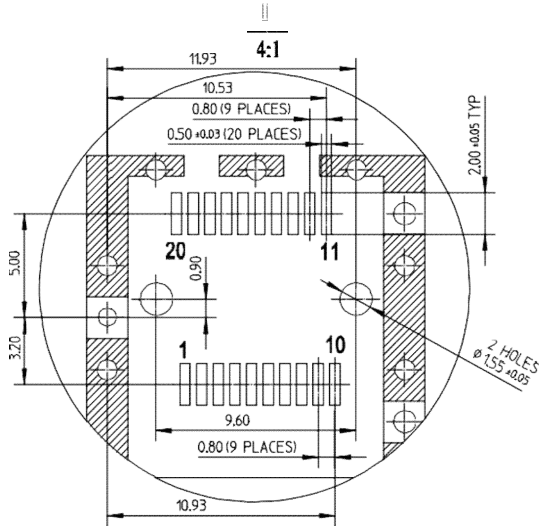

- Notes:**
1. Datum and basic dimensions established by customer
 2. Pads and vias are chassis ground, 11 places
 3. Thru holes, plating optional

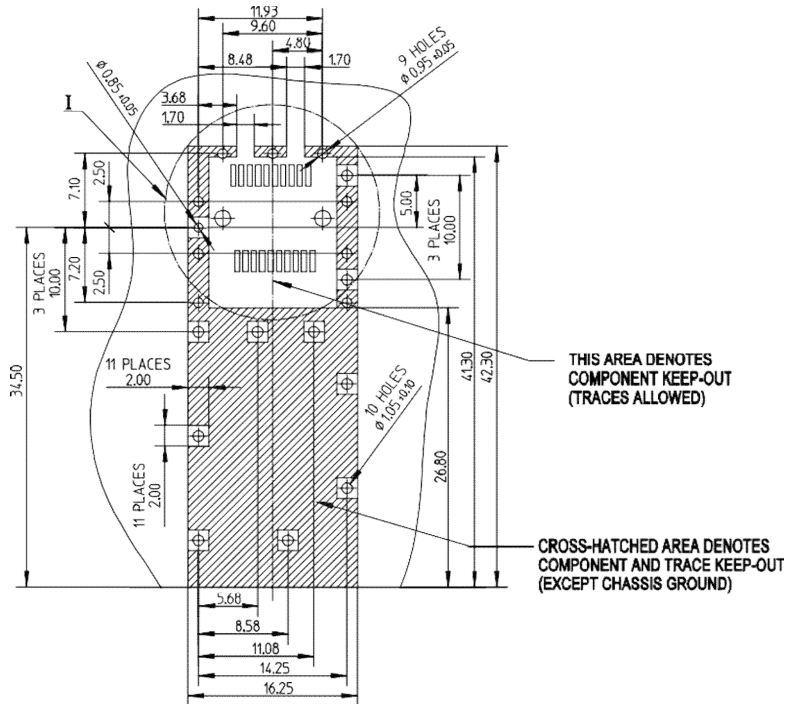

RECOMMENDED FRONT PANEL LAYOUT OPENING FOR LC

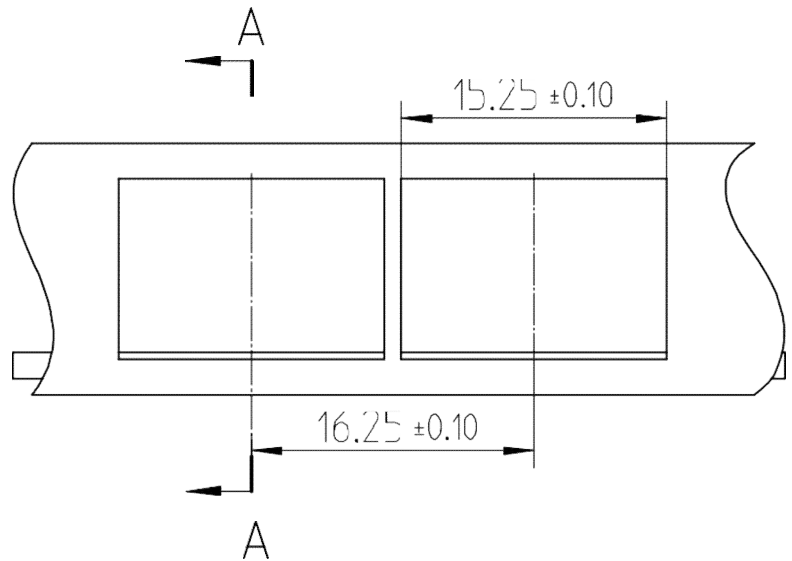
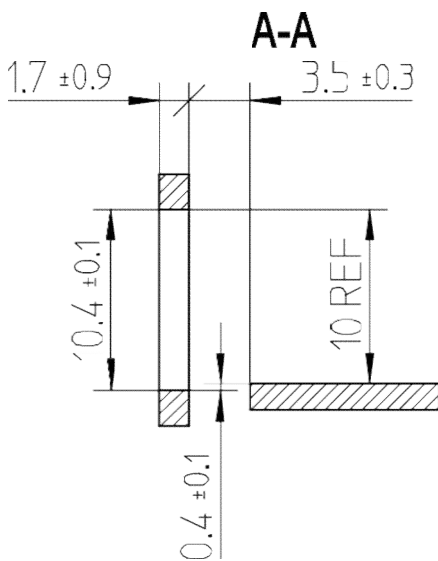

Mechanical Dimensions

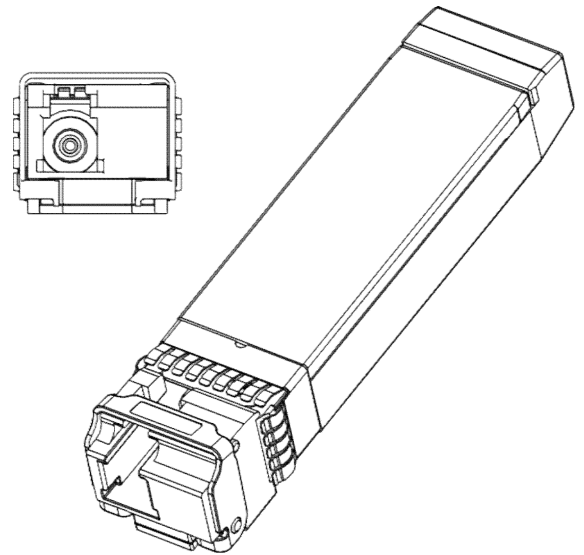
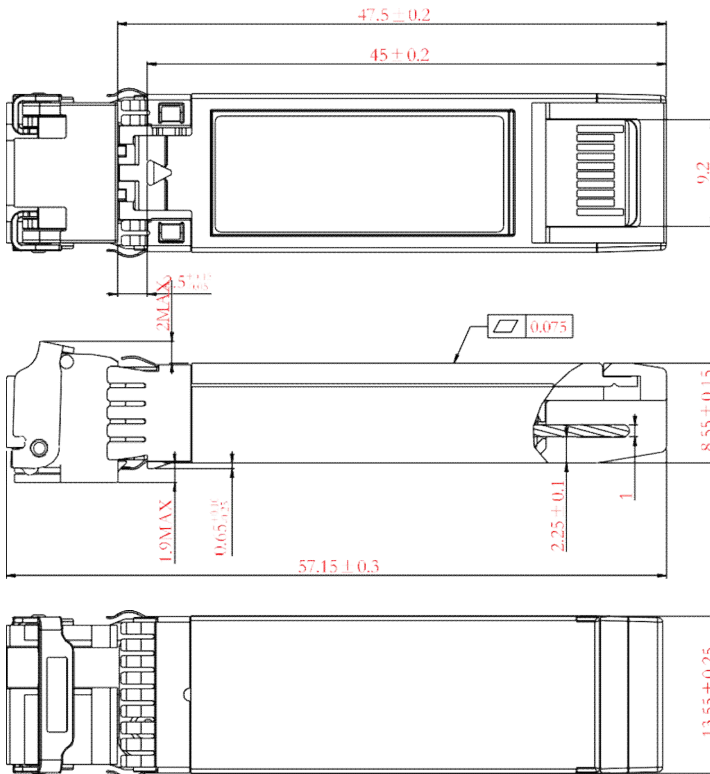

- NOTES:
1.TOLERANCE: +/-0.1MM
2.OTHERS ACCORDING WITH SFF-8074/SFF-8432 OR CUSTOMER SPEC.
3.LIGHT PORT ACCORDING WITH FIBER CONNECTOR SPEC.

Warnings

Handling Precautions:

This device is susceptible to damage as a result of electrostatic discharge (ESD). A static free environment is highly recommended. Follow guidelines according to proper ESD procedures.

Laser Safety:

Radiation emitted by laser devices can be dangerous to human eyes. Avoid eye exposure to direct or indirect radiation.

Notice:

The information provided on this page contains the product target specifications which are subject to change without notice.

Check with your Hisense Sales Office for product updates, changes in specifications, sample availability and production release dates



FH-SPB232TCDL40
25Gb/s SFP28 BIDI 1270/1330 LC 40KM DDMI

For More Information

FANG HANG TECH LIMITED

908 room, Jingyuan Building, 28 Bulong Rd, Longgang District, Shenzhen China

Tel: +86-755-89584520

Fax: +86-755-89584520

sales@fanghangtech.com

www.fanghangtech.com