

Product Features

- ✧ compliant to IEEE 802.3by
- ✧ compliant to SFF-8402 for SFP28 solution
- ✧ Digital Diagnostic Monitor Interface with SFF-8472
- ✧ Hot pluggable SFP+ footprint
- ✧ 1270nm /1330nm DFB transmitter
- ✧ Up to 25.78Gb/s data links
- ✧ Applicable for 10Km SMF connection
- ✧ High transmission margin
- ✧ Low power consumption<1.5W
- ✧ Single 3.3V power supply
- ✧ Operating case temperature: 0 to 70 ° C



Applications

- ✧ 25.78 Gb/s single lane
- ✧ Other optical links

Ordering Information

Part Number	Output Power	Rec. Sens	Data Rate	Wavelength	Distance
FH-SPB232TCDL10				<i>1270/1330nm</i>	
<i>FH-SPB322TCDL10</i>	<i>-7~+2dBm</i>	<i>-5.2dBm</i>	25.78G	<i>1330/1270nm</i>	<i>10km</i>

General

This 1270 /1330nm DFB 25.78Gbps SFP+ BIDI transceiver is designed for use in 25Gb/s data rate over single-mode fiber for link length 10Km.

The transceiver designs are optimized for high performance and cost effective to supply customers the best solutions for 25Gb/s single lane optical links.

Absolute Maximum Ratings

Parameter	Symbol	Min.	Max.	Unit	Note
Supply Voltage	Vcc	-0.5	4.0	V	
Storage Temperature		-40	85	°C	
Relative Humidity		0	85	%	

Note: Stress in excess of the maximum absolute ratings can cause permanent damage to the module

General Operating Characteristics

Parameter	Symbol	Min.	Typ	Max.	Unit	Note
Data Rate			25.78		Gb/s	
Supply Voltage	Vcc	3.13	3.3	3.47	V	
Supply current	Icc ₃			450	mA	
Operating Case Temp.	Tc	0		70	°C	

Electrical Input/Output Characteristics

Parameter	Symbol	Min.	Typical	Max.	Unit	Notes
Transmitter						
Diff. input voltage swing		120		820	mVpp	1
Tx Disable input	H	V _{IH}	2.0		V _{CC} +0.3	V
	L	V _{IL}	0		0.8	
Tx Fault output	H	V _{OH}	2.0		V _{CC} +0.3	V
	L	V _{OL}	0		0.8	
Input Diff. Impedance	Z _{in}		100		Ω	
Receiver						
Diff. output voltage swing		340	650	800	mVpp	3
Rx LOS Output	H	V _{OH}	2.0		V _{CC} +0.3	V
	L	V _{OL}	0		0.8	

Note 1) TD+/- are internally AC coupled with 100Ω differential termination inside the module.

Note 2) Tx Fault and Rx LOS are open collector outputs, which should be pulled up with 4.7k to 10kΩ resistors on the host board. Pull up voltage between 2.0V and V_{CC}+0.3V.

Note 3) RD+/- outputs are internally AC coupled, and should be terminated with 100Ω (differential) at the user SERDES.

Optical Characteristics

Parameter	Symbol	Min.	Typ	Max.	Unit	Note
Transmitter						
Operating Wavelength		1260	1270	1280	nm	
		1320	1330	1340		
Ave. output power (Enabled)	Po	-7		2	dBm	
Extinction Ratio	ER	3			dB	
spectral width(-20dB)	$\Delta\lambda$			1	nm	
Relative Intensity Noise	RIN			-128	ps	
Optical modulation amplitude	OMA	-6.4		3	dBm	
Dispersion penalty				3	dB	
Receiver						
Operating Wavelength		1320	1330	1340	nm	
		1260	1270	1280		
Stressed Receiver OMA Sensitivity	Rsen1			-5.2	dBm	
Min. overload	Pimax	-11		3	dBm	
LOS Assert	Pa	-30			dBm	
LOS De-assert	Pd			-14	dBm	
LOS Hysteresis	Pd-Pa	1		5	dB	

Pin Definitions And Functions

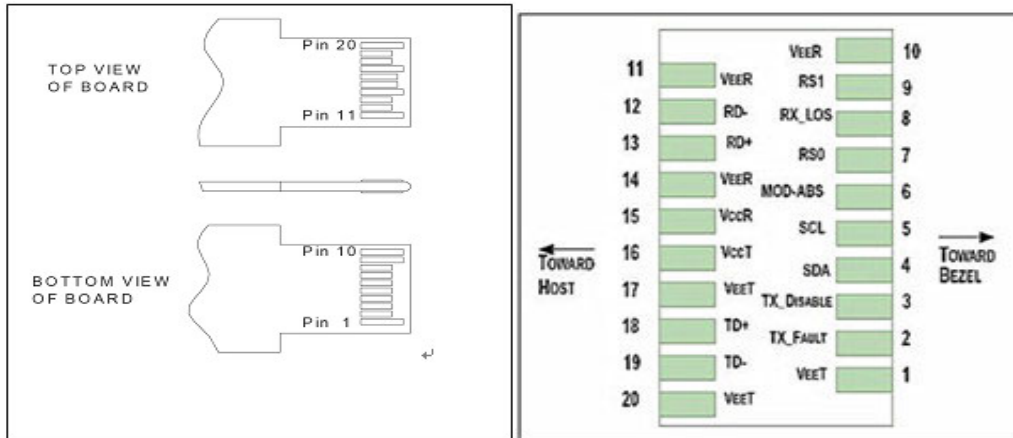

Pin	Symbol	Name/Description
1	VEET [1]	Transmitter Ground
2	Tx_FAULT [2]	Transmitter Fault
3	Tx_DIS [3]	Transmitter Disable. Laser output disabled on high or open
4	SDA [2]	2-wire Serial Interface Data Line
5	SCL [2]	2-wire Serial Interface Clock Line
6	MOD_ABS [4]	Module Absent. Grounded within the module
7	RS0 [5]	Rate Select 0
8	RX_LOS [2]	Loss of Signal indication. Logic 0 indicates normal operation
9	RS1 [5]	Rate Select 1
10	VEER [1]	Receiver Ground
11	VEER [1]	Receiver Ground
12	RD-	Receiver Inverted DATA out. AC Coupled
13	RD+	Receiver DATA out. AC Coupled
14	VEER [1]	Receiver Ground
15	VCCR	Receiver Power Supply
16	VCCT	Transmitter Power Supply
17	VEET [1]	Transmitter Ground
18	TD+	Transmitter DATA in. AC Coupled
19	TD-	Transmitter Inverted DATA in. AC Coupled
20	VEET [1]	Transmitter Ground

Notes:

- [1] Module circuit ground is isolated from module chassis ground within the module.
- [2].should be pulled up with 4.7k – 10k ohms on host board to a voltage between 3.15V and 3.6V.
- [3]Tx_Disable is an input contact with a 4.7 kΩ to 10 kΩ pullup to VccT inside the module.
- [4]Mod_ABS is connected to VeeT or VeeR in the SFP+ module. The host may pull this contact up to Vcc_Host with a resistor in the range 4.7 kΩ to 10 kΩ.Mod_ABS is asserted “High” when the SFP+ module is physically absent from a host slot.
- [5] RS0 and RS1 are module inputs and are pulled low to VeeT with > 30 kΩ resistors or NC in the module, don't use

Typical interface circuit

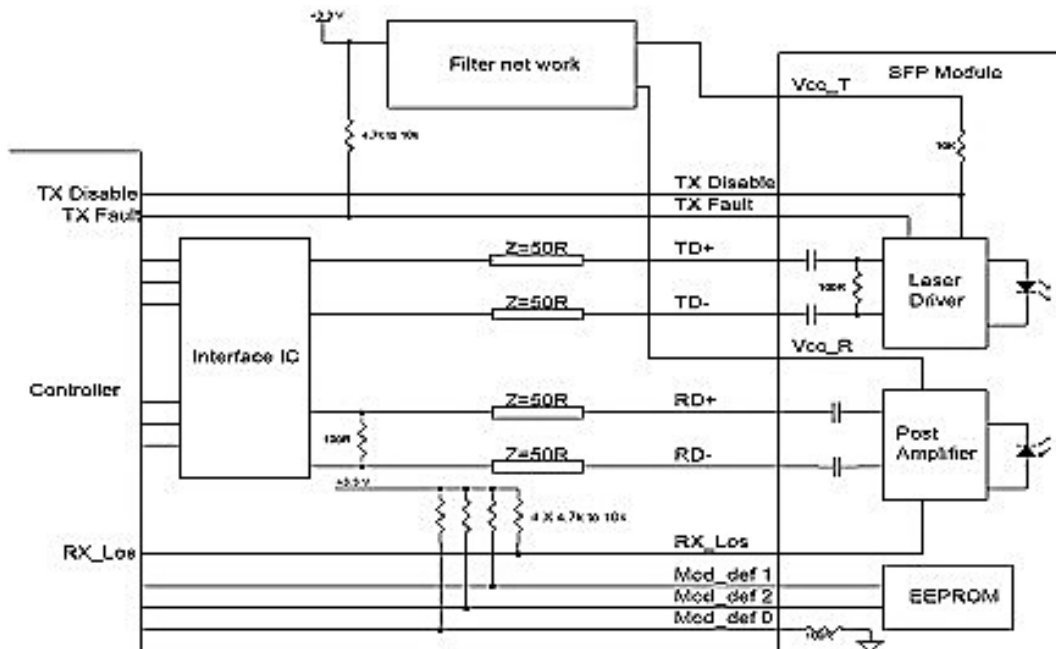

Recommended power supply filter

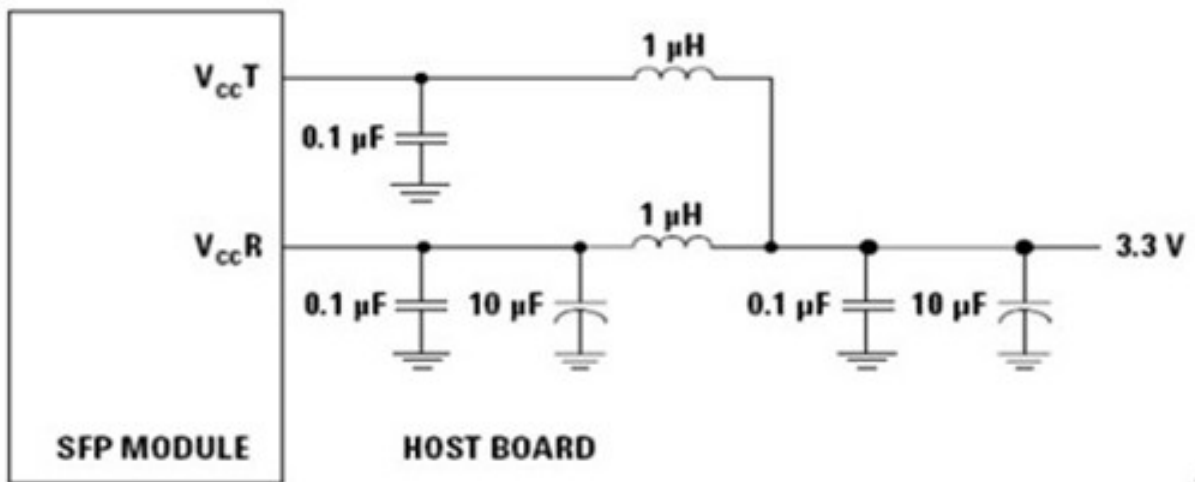

Note:

Inductors with DC resistance of less than 1Ω should be used in order to maintain the required voltage at the SFP input pin with 3.3V supply voltage. When the recommended supply filtering network is used, hot plugging of the SFP transceiver module will result in an inrush current of no more than 30 mA greater than the steady state value

Package Dimensions

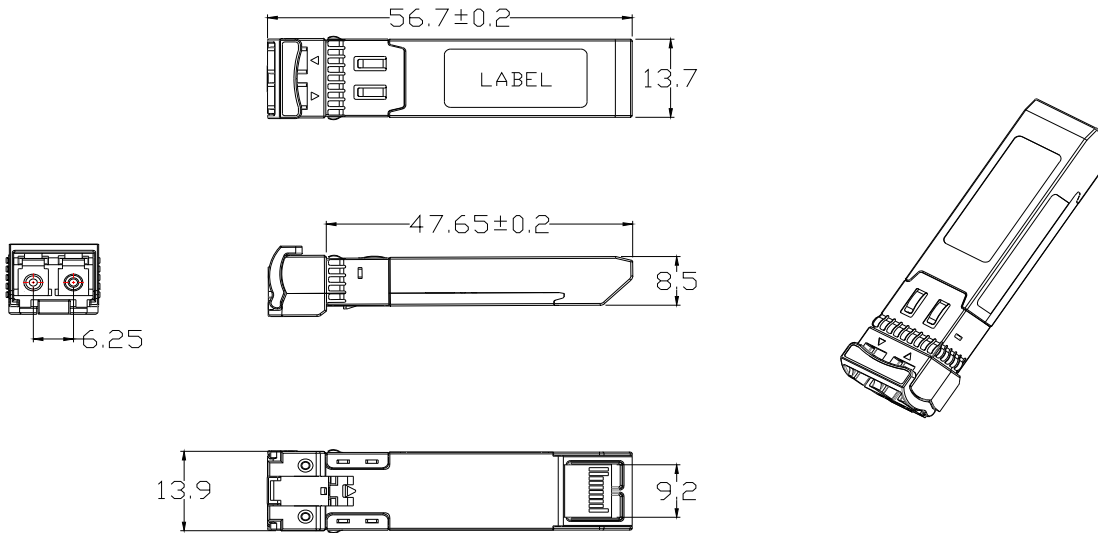

Dimensions are in Millimeter

Tolerance without indication is ± 0.1 mm

For More Information

FANG HANG TECH LIMITED

908 room, Jingyuan Building, 28 Bulong Rd, Longgang District, Shenzhen China

Tel: +86-755-89584520

Fax: +86-755-89584520

sales@fanghangtech.com

www.fanghangtech.com