

## Product Features

- ✧ Compliant with IEEE802.3ae
- ✧ Wavelength selectable to ITU-T standards covering CWDM grid wavelengths
- ✧ DFB transmitter and PIN receiver
- ✧ Digital Diagnostic Monitor Interface
- ✧ Hot pluggable
- ✧ link length up to 20km.
- ✧ Low power consumption
- ✧ Operating case temperature: 0 to 70 °C

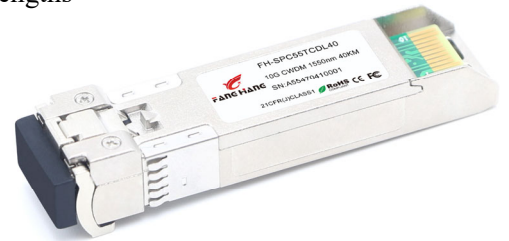

## Applications

- ✧ 10GBASE-LR at 10.3125Gbps
- ✧ CWDM Networks

## Ordering Information

Part Number	Output Power	Rec. Sens	Data Rate	Wavelength	Distance
FH-SPCxx1TCDL20D	-6~ 0 db	-12.6db	10.3G	1270-1610nm	20km

## General

FH-SPCxx1TCDL20D Optical transceivers SFP+ CWDM transceiver is designed to transmit and receive optical data over single mode optical fiber for link length 20km.

The transceiver consists of two sections: The transmitter section incorporates a DFB laser. And the receiver section consists of a PIN photodiode integrated with a TIA. All modules satisfy class I laser safety requirements. Digital diagnostics functions are available via a 2-wire serial interface, as specified in SFF-8472, which allows real-time access to device operating parameters such as transceiver temperature, laser bias current, transmitted optical power, received optical power and transceiver supply voltage.

## Absolute Maximum Ratings

Parameter	Symbol	Min.	Max.	Unit	Note
Supply Voltage	V <sub>cc</sub>	-0.5	4.0	V	
Storage Temperature		-40	85	°C	
Relative Humidity			85	%	

Note: Stress in excess of the maximum absolute ratings can cause permanent damage to the module

## General Operating Characteristics

Parameter	Symbol	Min.	Typ	Max.	Unit	Note
Data Rate	Ethernet		10.3125		Gb/s	
	Fiber Channel					
Supply Voltage	V <sub>cc</sub>	3.13	3.3	3.47	V	
	V <sub>cc</sub>				V	
Supply Current	I <sub>cc5</sub>				mA	
	I <sub>cc3</sub>			300	mA	
Operating Case Temp.	T <sub>c</sub>	0		70	°C	

## Electrical Input/Output Characteristics

Parameter	Symbol	Min.	Typ	Max.	Unit	Note
<b>Transmitter</b>						
Diff. input voltage swing		120		820	mVpp	1
Tx Disable input	H	VIH	2.0	Vcc+0.3	V	
	L	VIL	0	0.8		
Tx Fault output	H	VOH	2.0	Vcc+0.3	V	2
	L	VOL	0	0.8		
Input Diff. Impedance	Zin		100		Ω	
<b>Receiver</b>						
Diff. output voltage swing		340	650	800	mVpp	3
Rx LOS Output	H	VOH	2.0	Vcc+0.3	V	2
	L	VOL	0	0.8		

Note 1) TD+/- are internally AC coupled with 100Ω differential termination inside the module.

Note 2) Tx Fault and Rx LOS are open collector outputs, which should be pulled up with 4.7k to 10kΩ resistors on the host board.

Pull up voltage between 2.0V and Vcc+0.3V.

Note 3) RD+/- outputs are internally AC coupled, and should be terminated with 100Ω (differential) at the user SERDES.

## Optical Characteristics

Parameter	Symbol	Min.	Typ	Max.	Unit	Note
<b>Transmitter</b>						
Operating Wavelength			Xx		nm	4
Ave. output power (Enabled)	Po	-6		0	dBm	1
Extinction Ratio	ER	4			dB	1
RMS spectral width	$\Delta\lambda$			1	nm	
Rise/Fall time (20%~80%)	Tr/Tf			50	ps	2
Optical modulation amplitude	OMA	-6.2			dBm	
Dispersion penalty				1	dB	
Output Optical Eye	IEEE 802.3-2005 Compliant					
<b>Receiver</b>						
Operating Wavelength		1260		1610	nm	
Sensitivity	Psen			-12.6	dBm	3
Min. overload	Pimax	0.5			dBm	
LOS Assert	Pa	-30			dBm	
LOS De-assert	Pd			-11	dBm	
LOS Hysteresis	Pd-Pa	0.5		4	dB	

Note 1) Measured at 10.3125b/s with PRBS 2<sup>31</sup> – 1 NRZ test pattern.

Note 2) 20%~80%

Note 3) Under the ER worst case, measured at 10.3125 Gb/s with PRBS 2<sup>31</sup> - 1 NRZ test pattern for BER < 1x10<sup>-12</sup>

Note 4) If there is CWDM Product ,the wavelength XX — 1470nm~1610nm

## Pin Definitions And Functions

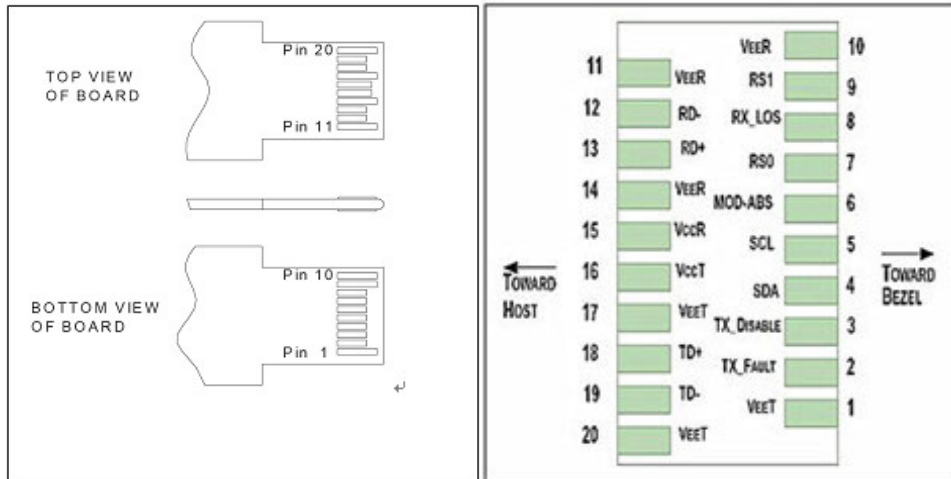

Pin	Symbol	Name/Description
1	VEET [1]	Transmitter Ground
2	Tx_FAULT [2]	Transmitter Fault
3	Tx_DIS [3]	Transmitter Disable. Laser output disabled on high or open
4	SDA [2]	2-wire Serial Interface Data Line
5	SCL [2]	2-wire Serial Interface Clock Line
6	MOD_ABS [4]	Module Absent. Grounded within the module
7	RS0 [5]	Rate Select 0
8	RX_LOS [2]	Loss of Signal indication. Logic 0 indicates normal operation
9	RS1 [5]	Rate Select 1
10	VEER [1]	Receiver Ground
11	VEER [1]	Receiver Ground
12	RD-	Receiver Inverted DATA out. AC Coupled
13	RD+	Receiver DATA out. AC Coupled
14	VEER [1]	Receiver Ground

15	VCCR	Receiver Power Supply
16	VCCT	Transmitter Power Supply
17	VEET [1]	Transmitter Ground
18	TD+	Transmitter DATA in. AC Coupled
19	TD-	Transmitter Inverted DATA in. AC Coupled
20	VEET [1]	Transmitter Ground

[1] Module circuit ground is isolated from module chassis ground within the module.

[2].should be pulled up with 4.7k – 10k ohms on host board to a voltage between 3.15V and 3.6V.

[3]Tx\_Disable is an input contact with a 4.7 kΩ to 10 kΩ pullup to VccT inside the module.

[4]Mod\_ABS is connected to VeeT or VeeR in the SFP+ module. The host may pull this contact up to Vcc\_Host with a resistor in the range 4.7 kΩ to 10 kΩ.Mod\_ABS is asserted “High” when the SFP+ module is physically absent from a host slot.

[5] RS0 and RS1 are module inputs and are pulled low to VeeT with > 30 kΩ resistors in the module.

## Functional Diagram

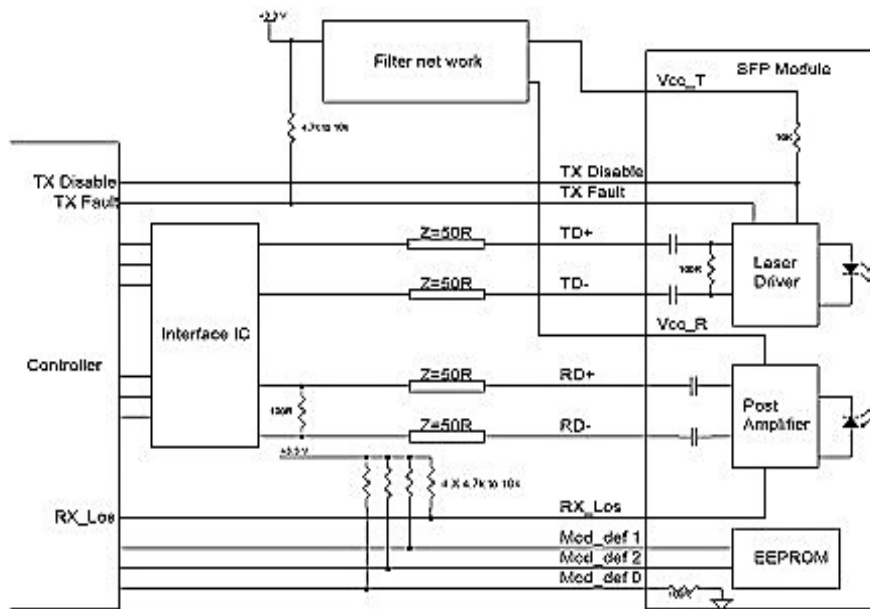

### Recommended power supply filter

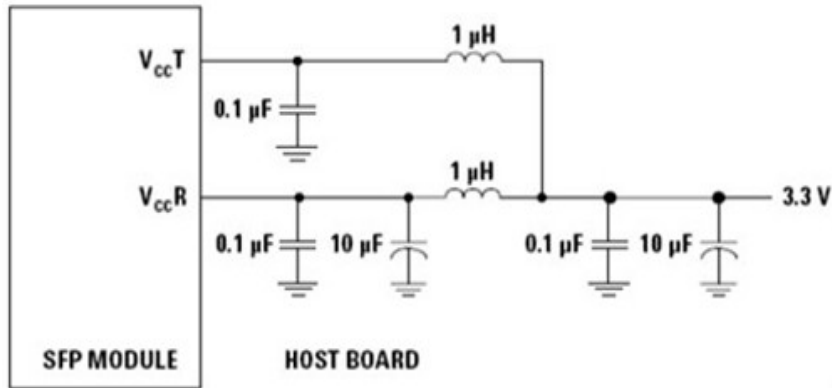

Note: Inductors with DC resistance of less than  $1\Omega$  should be used in order to maintain the required voltage at the SFP input pin with 3.3V supply voltage. When the recommended supply filtering network is used, hot plugging of the SFP transceiver module will result in an inrush current of no more than 30 mA greater than the steady state value

### Package Dimensions

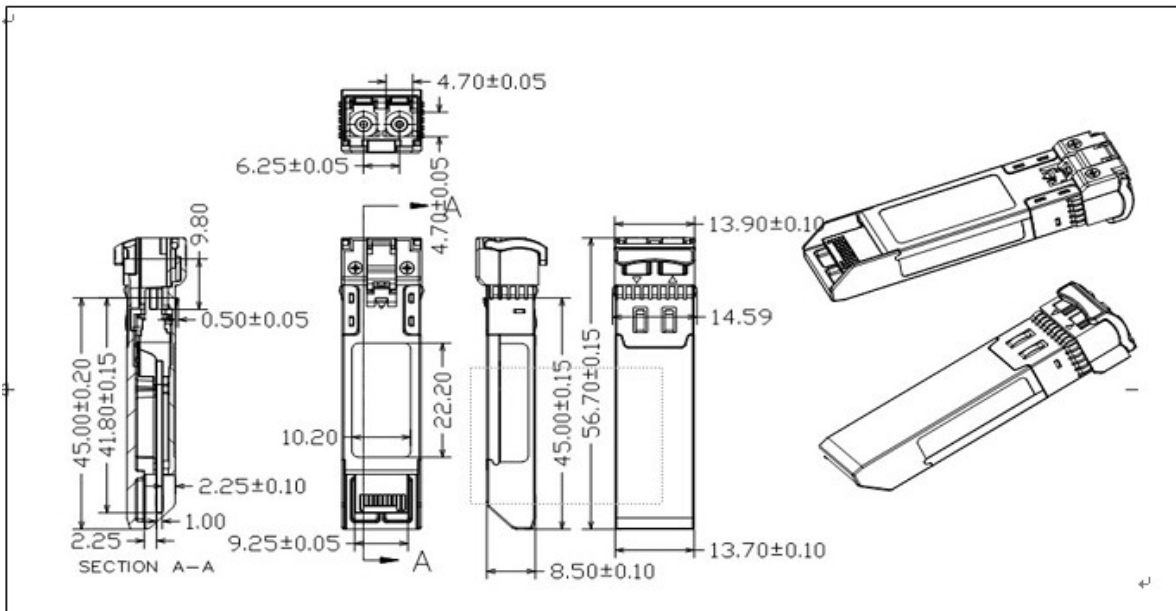



*FH-SPCXX1TCDL20D*  
*10G SFP+ CWDM XXnm 20km DDMI LC*

## **For More Information**

FANG HANG TECH LIMITED

Add: Room 908, Jingyuan Building, 28 Bulong Rd, Longgang District, Shenzhen China

Tel: +86-755-89584520

Fax: +86-755-89584520

[sales@fanghangtech.com](mailto:sales@fanghangtech.com)

[www.fanghangtech.com](http://www.fanghangtech.com)